



August 2, 2024

TO ALL HOLDERS OF BIDDING DOCUMENTS:

SUBJECT: ADMINISTRATION AND EARLY LEARNING CENTER ADDITIONS
ORCHARD FARM R-V SCHOOL DISTRICT
ST. CHARLES, MISSOURI
PROJECT # 23-09C

Enclosed please find one (1) electronic .pdf copy of Addendum No. 2, dated August 1, 2024, for the above-named project.

Addendum No. 2 is being EMAILED to the General Contractors, Subcontractors and Plan Rooms on the Plan Holders List at Hoener Associates.

BID DATE: The bids are due at 2:00 p.m. CDT, on Thursday, August 8, 2024.

BID LOCATION: Sealed bids will be received by the Orchard Farm R-V School District, Orchard Farm Administration Office, 3489 Boschertown Road, St. Charles, MO.

Please notify the appropriate subcontractors and/or suppliers of this addendum.

Sincerely,

HOENER ASSOCIATES, INC.

Matt McDermott, Project Manager

ORCHARD FARM R-V SCHOOL DISTRICT
ADMINISTRATION AND OFFICE ADDITIONS
ST. CHARLES, MISSOURI

AUGUST 1, 2024

The drawings and specifications are hereby supplemented and amended to include the following particulars:

GENERAL

ITEM NO. 1: GENERAL QUESTIONS

- A. **Q:** Please provide the existing fire protection drawings for the existing building. **A: Documents are included with this addendum.**

ARCHITECTURAL

ITEM NO. 2: ARCHITECTURAL SUPPLEMENTARY DRAWINGS

- A. Supplementary Drawings SD 11 (A2.2), SD 17 (DA 1.01A), SD 18 (DA 7.05), SD 19 (A1.4), SD 20 (DA 8.01a) and SD 21 (DA 8.01b) included with this Addendum and hereby made a part of the contract documents.

ITEM NO. 3: ARCHITECTURAL SPECIFICATION SECTION 08701 – DOOR HARDWARE

- A. Subparagraph 4.1, J., Group No. 10: **“Add”** the following doors to this group: Door 313, 314, 315, 316, 317, and 318.

MECHANICAL SPECIFICATIONS

ITEM NO. 4 – SPECIFICATION SECTION 20 00 50 A

- A. **“REVISE”** Contractor warranties to be for 2 years after final acceptance for all materials and workmanship.

ITEM NO. 5 – SPECIFICATION SECTION 23 50 01 C

- A. **“REVISE”** minimum warranty of 24 months from startup.

ITEM NO. 6 – SPECIFICATION SECTION 23 70 01

- A. **“ADD”** Rooftop Unit Noise Reduction System.
1. The noise reduction system shall be a multi-layered acoustical composite for placement inside the rooftop equipment curbs. The overall installed thickness of the composite panels shall be 7”. All materials shall meet Class “A” flame spread and smoke develop as per the inside the curb. Decking shall be maintained inside the RTU curb to a clearance of ¼” maximum. The manufacturer or their local authorized agent shall inspect the in-curb deck system work on site prior to installation of the RTUs on the roof curbs and issue a letter of certification to the engineer. The system shall be provided by the rooftop unit manufacturer as a turnkey package.
 2. The in-curb acoustical treatment performance shall be tested in accordance with ASTM E-90-10, The assembly shall be rated at not less than STC-52 with 1/3 octave performance values as listed below for sound radiation throughout the deck inside the curb.

In-Curb Composite - (Transmission Loss) in accordance with ASTM E-90-10																						
Freq. (Hz)	80	100	125	160	200	250	315	400	500	630	800	1K	1.25K	1.6K	2K	2.5K	3.15K	4K	5K	6.3K	8K	STC
Transmission Loss (dB)	26	27	33	32	35	42	45	45	50	56	59	60	62	63	64	65	67	71	74	78	80	52

3. System shall be by manufacturer BRD Noise and Vibration Control, Inc. model Hushcore Deck System model DS-52 or approved equal.

ITEM NO. 7 – SPECIFICATION SECTION 23 70 01

- A. “ADD” Unit shall have a minimum warranty of 24 months from startup.

ITEM NO. 8 – SPECIFICATION SECTION 23 70 02

- A. “ADD” Unit shall have a minimum warranty of 24 months from startup.

ITEM NO. 9 – SPECIFICATION SECTION 23 34 01 J

- A. “ADD” Unit shall have a minimum warranty of 24 months from startup.

MECHANICAL DRAWINGS

ITEM NO. 10 – MECHANICAL DRAWING SHEET M3.1

- A. “REVISE” Shift position of RTU-7 as indicated.

ITEM NO. 11 – MECHANICAL DRAWING SHEET M3.3

- A. “REVISE” Shift position of RTU-7 as indicated.

ELECTRICAL SPECIFICATIONS

ITEM NO. 12 – SPECIFICATION SECTION 28 13 00

- A. “REVISE” 1.2 SUMMARY.
 1. The option for an S2 type system included as an option along with Lenel. Lenel equipment confirmed to be backwards compatible with the new S2 software system.

ELECTRICAL DRAWINGS

ITEM NO. 13 – ELECTRICAL DRAWING SHEET E4.1

- A. “ADD” GENERAL NOTES
 1. Added general note #10 to clarify crossover between existing and new scope.
- B. “ADD” KEYED NOTES
 1. Added keyed note #1 to clarify the owner-preferred installation method of new door access controls.

ITEM NO. 14 – ELECTRICAL DRAWING SHEET E4.2

- A. “ADD” GENERAL NOTES
 1. Added general note #10 to clarify crossover between existing and new scope.

B. **“ADD”** KEYED NOTES

1. Added keyed note #1 to clarify the owner-preferred installation method of new door access controls.
2. Added keyed note #2 to clarify possible need for a CPU upgrade within the head-end equipment. This shall be coordinated with the owner and Tech Electronics prior to work being completed.

END OF ADDENDUM #2

SUBMITTAL REVIEW

Date Received: 12/15/2015	Date Returned: 1/19/2016
Project Number: 104306.000	Reviewer: Billy Lewis
Project Name Orchard Farm School District - Early Childhood Center	
Contractor Submittal Number	

We are returning the following submittals with action as noted:
 APPROVED (A)
 APPROVED AS CORRECTED (AAC)
 REVISE AND RESUBMIT (R&R)
 NOT APPROVED (NA)
 REVIEWED (R)

These documents were reviewed with the understanding that they were submitted after the contractor reviewed them and implicitly certified that they were in compliance in all respects with the requirements of the contract documents. Checking is only for conformance with the design concept of the project and compliance with the information given in the Contract Documents. Contractor is responsible for quantities; dimensions to be confirmed and correlated at the job site; for information that pertains solely to the fabrication processes or to techniques of construction; and for coordination of the work of all trades.

Description Comments	A	AAC	R&R	NA	R
Fire Sprinkler Calcs and Drawings Contractor shall review and address all comments made with the return shop drawing submittal. Contractor shall provide the following cut sheets for review: 1. Fire Department Connection. 2. All signage. 3. All piping and fittings. 4. All hanging and bracing components. 5. Corrected/approved sprinklers. 6. Hose valves (to be used for backflow testing). 7. Spare sprinkler cabinet. 8. Flexible sprinkler piping. 9. Tamper Switches. 10. All gauges.			✓		

SHOP DRAWING SUBMITTAL

PROJECT: Orchard Farm Early Childhood Center and Administration Complex

PROJECT NUMBER: 14-09E

GENERAL CONTRACTOR: Lamb Construction Company
205 E. Elm
O'Fallon, MO 63366
(636) 240-7907

ARCHITECT: Hoener Associates, Inc.
6707 Plainview Avenue
St. Louis, Missouri 63109
(314) 781-9855

DATE OF SUBMITTAL: December 15, 2015

SUBCONTRACTOR/SUPPLIER: Accurate Fire Protection Systems
1428 Gravois Road
High Ridge, MO 63049
(636) 677-9190

SPECIFICATION SECTION: 210000

PRODUCTS: Fire Sprinklers

CONTRACTOR'S REVIEW

ARCHITECT/ENGINEER'S REVIEW

CONTRACTOR SHALL REVIEW AND ADDRESS ALL COMMENTS MADE WITHIN RETURNED SHOP DRAWING SUBMITTAL.

CONTRACTOR SHALL PROVIDE THE FOLLOWING CUT SHEETS FOR REVIEW:

- FIRE DEPARTMENT CONNECTION
- ALL SIGNAGE
- ALL PIPING AND FITTINGS
- ALL HANGING AND BRACING COMPONENTS
- CORRECTED/APPROVED SPRINKLERS
- HOSE VALVES (TO BE USED FOR BACKFLOW TESTING)
- SPARE SPRINKLER CABINET
- FLEXIBLE SPRINKLER PIPING
- TAMPER SWITCHES
- ALL GAUGES

END OF SECTION 01300



1428 GRAVOIS RD.
HIGH RIDGE, MO 63049

PHONE: 636-677-9190
FAX: 636-677-9191

FIRE PROTECTION

EQUIPMENT SUBMITTAL

Job Name:

**ORCHARD FARM
EARLY CHILDHOOD
& ADMINISTRATIVE COMPLEX**
3489 BOSCHERTOWN RD & ISLAND HARBOR DR.
ST. CHARLES, MO.



Colt™ Series C200, C200N

Double Check Valve Assemblies

Sizes: 2½" – 10" (65 – 250mm)

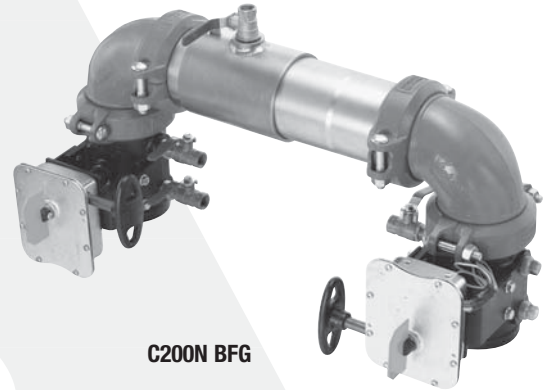
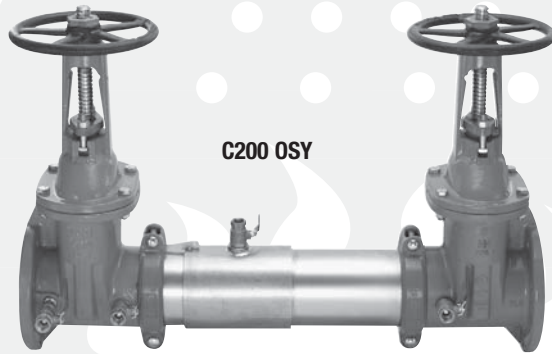

Features

- Extremely Compact Design
- 70% Lighter than Traditional Designs
- 304 (Schedule 40) Stainless Steel Housing & Sleeve
- Groove Fittings Allow Integral Pipeline Adjustment
- Patented Tri-Link Check Provides Lowest Pressure Loss
- Unmatched Ease of Serviceability
- Available with Grooved Butterfly Valve Shutoffs
- Available for Horizontal, Vertical or N Pattern Installations
- Replaceable Check Disc Rubber

The Colt C200, C200N Double Check Valve Assemblies are used to prevent backflow of pollutants, that are objectionable but not toxic, from entering the potable water supply system. The Colt C200, C200N may be installed under continuous pressure service and may be subjected to backpressure. The Colt C200, C200N consists of two independently operating check valves, two shutoff valves, and four test cocks. For use in non-health hazard applications.

Specifications

The Colt C200, C200N Double Check Valve Assembly shall consist of two independent Tri-Link Check modules within a single housing, sleeve access port, four test cocks and two drip tight shutoff valves. Tri-Link Checks shall be removable and serviceable, without the use of special tools. The housing shall be constructed of 304 (Schedule 40) stainless steel pipe with groove end connections. Tri-Link checks shall have reversible elastomer discs and in operation shall produce drip tight closure against the reverse flow of liquid caused by backpressure or backsiphonage. Assembly shall be a Colt C200, C200N as manufactured by the Ames Company.

Job Name _____ Contractor _____

Job Location _____ Approval _____

Engineer _____ Contractor's P.O. No. _____

Approval _____ Representative _____

Ames product specifications in U.S. customary units and metric are approximate and are provided for reference only. For precise measurements, please contact Ames Technical Service. Ames reserves the right to change or modify product design, construction, specifications, or materials without prior notice and without incurring any obligation to make such changes and modifications on Ames products previously or subsequently sold.

Configurations

- Horizontal
- Vertical up
- “N” pattern horizontal

Materials

- Housing & Sleeve: 304 (Schedule 40) Stainless Steel
- Elastomers: EPDM, Silicone and Buna ‘N’
- Tri-Link Checks: Noryl®, Stainless Steel
- Check Discs: Reversible Silicone or EPDM
- Test Cocks: Bronze Body Nickel Plated
- Pins & Fasteners: 300 Series Stainless Steel
- Springs: Stainless Steel

Available Models

Suffix:

NRS - non-rising stem resilient seated gate valves

OSY - UL/FM outside stem and yoke, resilient seated gate valves

BFG - UL/FM grooved gear operated butterfly valves with tamper switch

*OSY FxG - Flanged inlet gate connection and grooved outlet gate connection

*OSY GxF - Grooved inlet gate connection and flanged outlet gate connection

*OSY GxG - Grooved inlet gate connection and grooved outlet gate connection

Available with grooved NRS gate valves - consult factory*

Post indicator plate and operating nut available - consult factory*

*Consult factory for dimensions

Pressure — Temperature

Temperature Range: 33°F – 110°F (5°C – 43°C)

Maximum Working Pressure: 175psi (12.06 bar)

Dimensions — Weights

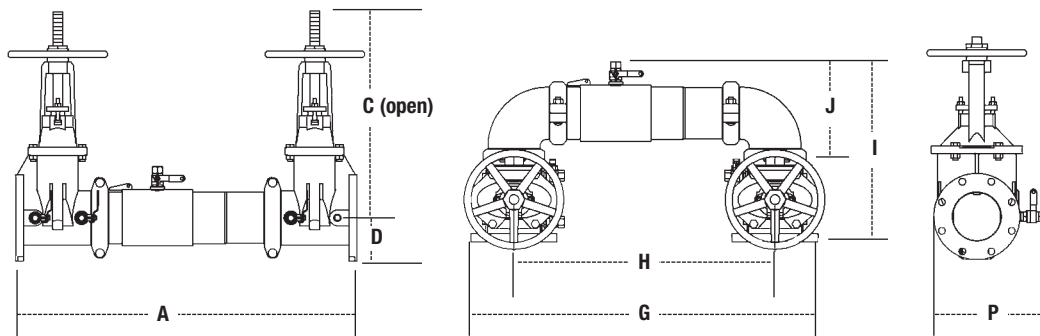

C200, C200N

SIZE (DN)		DIMENSIONS										WEIGHT															
in.	mm	A	C (OSY)	C (NRS)	D	G	H	I	J	P	C200NRS	C200OSY	C200N NRS	C200N OSY													
		in.	mm	in.	mm	in.	mm	in.	mm	in.	mm	in.	mm	in.	mm	lbs.	kgs.	lbs.	kgs.	lbs.	kgs.	lbs.	kgs.				
2½	65	31	787	16⅞	416	9⅞	238	3½	89	29⅞	738	22	559	15½	393	8⅜	223	9⅞	234	115	52	125	57	123	56	133	60
3	80	31⅞	805	18⅞	479	10¼	260	3⅞	94	30⅞	768	22¼	578	17⅞	435	9⅞	233	10½	267	131	59	145	66	144	65	158	72
4	100	33⅞	856	22¾	578	12⅞	310	4	102	33	838	24	610	18½	470	9⅞	252	11⅞	284	161	73	161	73	184	83	184	83
6	150	43½	1105	30⅞	765	16	406	5½	140	44¾	1137	33¾	857	23⅞	589	13⅞	332	15	381	273	124	295	134	314	142	336	152
8	200	50	1270	37¾	959	19⅞	506	6⅞	170	54⅞	1375	40⅞	1032	27⅞	697	15⅞	399	17⅞	437	438	199	480	218	513	233	555	252
10	250	57½	1460	45¾	1162	23⅞	605	8⅞	208	66	1676	50	1270	32½	826	17⅞	440	20	508	721	327	781	354	891	404	951	431

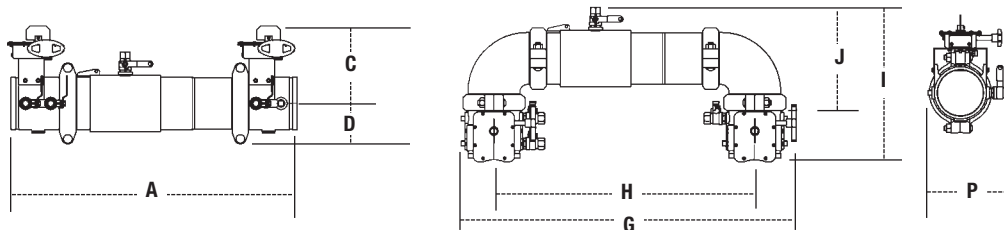

C200BFG, C200NBFG

SIZE (DN)		DIMENSIONS										WEIGHT									
in.	mm	A	C	D	G	H	I	J	P	C200BFG	C200NBFG										
		in.	mm	in.	mm	in.	mm	in.	mm	in.	mm	in.	mm	in.	mm	lbs.	kgs.	lbs.	kgs.		
2½	65	28	711	8	203	3½	89	29⅞	759	22	559	14⅞	379	8⅜	223	9	229	56	25	64	29
3	80	28½	724	8⅞	211	3⅞	94	30⅞	779	22¼	578	15⅞	392	9⅞	233	9½	241	54	24	67	30
4	100	29⅞	741	8⅞	227	3⅞	94	31⅞	811	24	610	16¼	412	9⅞	252	10	254	61	28	84	38
6	150	36½	927	10	254	5	127	43⅞	1097	33¾	857	19⅞	500	13⅞	332	10½	267	117	53	157	71
8	200	43	1092	12¼	311	6½	165	51⅞	1297	40⅞	1032	23⅞	592	15⅞	399	14⅞	361	261	118	337	153

Noryl® is a registered trademark of General Electric Company.

Approvals



1015



28S6



B64.4



Approved

For additional approval information please contact the factory or visit our website at www.amesfirewater.com

Capacity

UL/FM Certified Flow Characteristics

Flow characteristics collected using butterfly shutoff valves.

See literature S-Colt-200/300 for gate valve flow characteristics

* = Rated Flow ** = UL Tested

—— Horizontal —— Vertical - - - - - N - Pattern

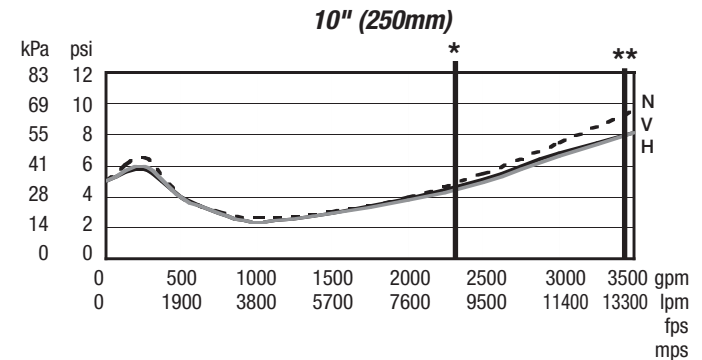
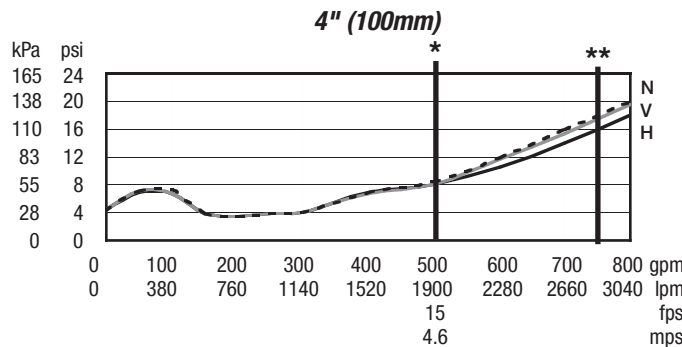
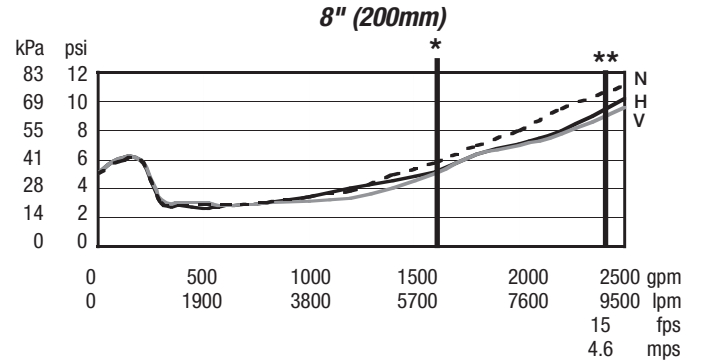
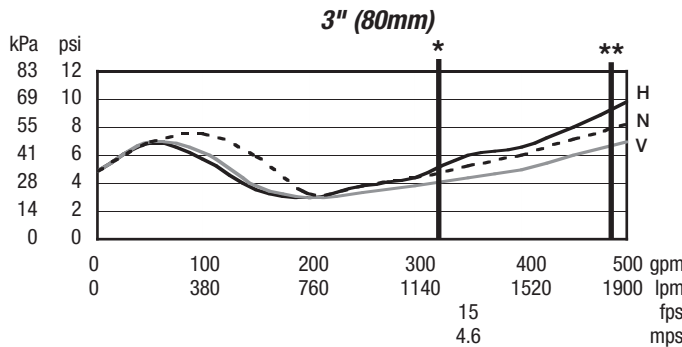
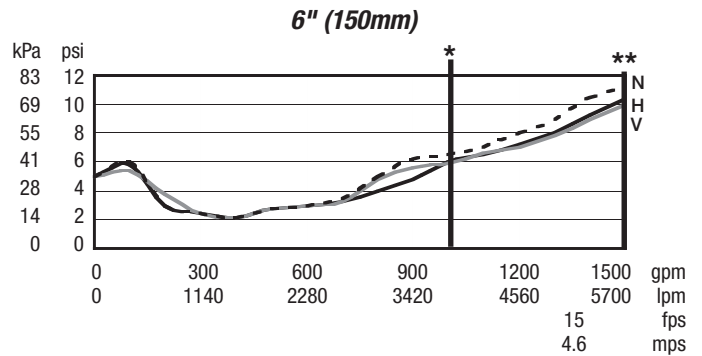
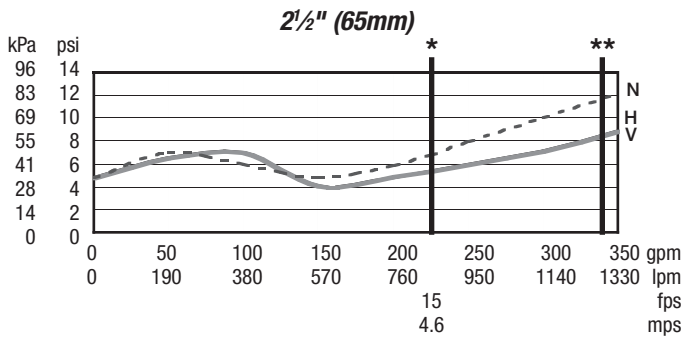

IMPORTANT: INQUIRE WITH GOVERNING AUTHORITIES FOR LOCAL INSTALLATION REQUIREMENTS

FireLock® Butterfly Valve



**SERIES 705W
WITH WEATHERPROOF ACTUATOR**

The Series 705W butterfly valve features an approved weatherproof actuator housing approved for indoor or outdoor use. It has a ductile iron body and disc with EPDM disc coating. The body is coated with a heat fused polyphenylene sulfide blend to meet FM requirements. Designed for fire protection services only. Series 705W valve is UL Listed and FM Approved for 300psi/2065kPa service. Contact Victaulic for details of agency approvals.



WEATHERPROOF ACTUATOR

Supervisory switches that monitor the valve in the fully open position for valves are available 2½ – 12”/65 – 300mm pre-wired (PW).

OPTIONAL SUPPLY-SIDE TAP

Series 705W valves are available with a ½” NPT supply side tap designed to allow direct water supply connection to Victaulic FireLock actuated fire protection valves. See separate drawings below. This is an optional feature and must be clearly noted on all orders.

MATERIAL SPECIFICATIONS

Body: Ductile iron conforming to ASTM A-536, coated with polyphenylene sulfide blend.

Disc: Ductile iron conforming to ASTM A-536, various grades, EPDM coated.

Disc Coating:

- **Grade “E” EPDM**

EPDM (Green color code). Temperature range –30°F to +230°F/–34°C to +110°C. Recommended for cold and hot water service within the specified temperature range plus a variety of dilute acids, oil-free air and many chemical services. UL classified in accordance with ANSI/NSF 61 for cold +86°F/+30°C and hot +180°F/+82°C potable water service. NOT RECOMMENDED FOR PETROLEUM SERVICES.

Stem Bearings: Teflon impregnated fiberglass with stainless steel backing.

Stem Bearing Nuts: Type 416 Stainless Steel.

Tap Plug: Carbon steel, plated.

O-Ring: EPDM

Bracket: Carbon steel, painted.

Actuator:

- 2½ – 8”/65 – 200mm: Bronze traveling nut on a steel lead screw, in a ductile iron housing.
- 10 – 12”/250 – 300mm: Steel worm and cast iron quadrant gear, in a cast iron housing.

JOB/OWNER

System No. _____
Location _____

CONTRACTOR

Submitted By _____
Date _____

ENGINEER

Spec Sect _____ Para _____
Approved _____
Date _____

FireLock® Butterfly Valve

**SERIES 705W
WITH WEATHERPROOF ACTUATOR**



Size		Dimensions – inches/millimeters								Aprx. Wgt. Each
Nominal Size inches/mm	Actual Outside Diameter inches/mm	End to End "A"	Hgt. "B"	"E"	"F"	"J"	"O"	"N" ‡	"P" ‡	lbs/kg
2½ 65	2.875 73.0	3.77 95.6	8.76 222.5	—	4.21 106.9	6.08 154.4	3.00 76.2	0.00 * 0.0 *	0.75 19.1	8.3 3.8
76.1 mm	3.000 76.1	3.77 95.6	8.76 222.5	—	4.21 106.9	6.08 154.4	3.00 76.2	0.00 * 0.0 *	0.75 19.1	8.3 3.8
3 80	3.500 88.9	3.77 95.6	9.40 238.8	0.08 2.0	4.21 106.9	6.08 154.4	3.00 76.2	0.00 * 0.0 *	0.75 19.1	8.9 4.0
4 100	4.500 114.3	4.63 117.6	10.84 275.3	0.07 1.8	6.01 152.7	6.98 177.3	3.00 76.2	0.73 18.5	1.13 28.7	14.9 6.8
139.7 mm	5.500 139.7	5.88 149.4	12.38 314.5	0.43 10.9	6.01 152.7	8.57 217.7	4.50 114.3	—	—	21.0 9.5
5 125	5.563 141.3	5.88 149.4	12.38 314.5	0.43 10.9	6.01 152.7	8.57 217.7	4.50 114.3	—	—	21.0 9.5
165.1 mm	6.500 165.1	5.88 149.4	13.41 340.6	1.00 25.4	7.51 190.8	9.32 236.7	4.50 114.3	1.60 40.6	1.88 47.8	26.5 12.0
6 150	6.625 168.3	5.88 149.4	13.41 340.6	1.00 25.4	7.51 190.8	9.32 236.7	4.50 114.3	1.60 40.6	1.88 47.8	26.5 12.0
8 200	8.625 219.1	5.33 135.4	16.50 419.1	1.27 32.3	9.65 245.1	10.98 278.9	6.30 160.0	0.00 * 0.0 *	0.68 17.3	43.0 19.5
10 250	10.750 273.0	6.40 162.6	19.14 486.2	1.72 43.7	12.20 309.9	16.19 411.2	9.00 228.6	—	—	80.0 36.3
12 300	12.750 323.9	6.50 165.1	21.54 547.1	2.66 67.6	14.25 362.0	17.22 437.4	9.00 228.6	—	—	102.0 46.3

* On Centerline

‡ These dimensions apply only to a Series 705W Butterfly Valve with a ½-inch NPT, supply-side tap

1. To prevent rotation of valves, it is recommended that Series 705W be installed with Victaulic Style 07 Zero-Flex®, Style 005 FireLock, Style 009/009V FireLock EZ, or Style HP-70 Rigid Couplings. If Victaulic flexible couplings are used, additional support may be required.
2. Valve must not be installed with disc in full open position. Disc must be partly closed so that no part is protruding beyond end of valve body.
3. Victaulic grooved end butterfly valves are permitted for use with grooved end pipe (IPS) only. Not permitted for use with plain end (IPS) pipe.
4. Series 705W valves are designed for ambient weather conditions as opposed to submersible service.

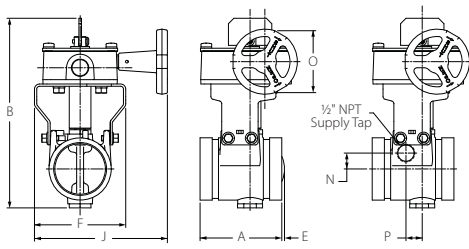

2½ – 4-INCH/65 – 100-MM SIZES

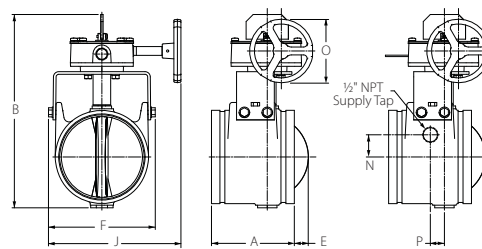

5 – 12-INCH/125 – 300-MM SIZES

FireLock® Butterfly Valve

**SERIES 705W
WITH WEATHERPROOF ACTUATOR**

SWITCH AND WIRING

1. The supervisory switch contains two, single pole, double throw, pre-wired switches.
2. Switches are rated:
 - 10 amps @ 125 or 250 VAC/60 Hz
 - 0.50 amps @ 125 VDC
 - 0.25 amps @ 250 VDC
3. Switches supervise the valve in the “open” position.
4. One switch has two #18 MTW wires per terminal, which permit complete supervision of leads (refer to diagrams and notes below). The second switch has one #18 MTW wire per terminal. This double circuit provides flexibility to operate two electrical devices at separate locations, such as an indicating light and an audible alarm, in the area that the valve is installed.
5. A #14 MTW ground lead (green) is provided.

Switch #1 = S1 For connection to the supervisory circuit of a UL Listed alarm control panel
 Switch #2 = S2 Auxiliary switch that may be connected to auxiliary devices, per the authority having jurisdiction

- S1 { Normally Closed: (2) Blue
Common: (2) Yellow
- S2 { Normally Closed: Blue with Orange Stripe
Normally Open: Brown with Orange Stripe
Common: Yellow with Orange Stripe

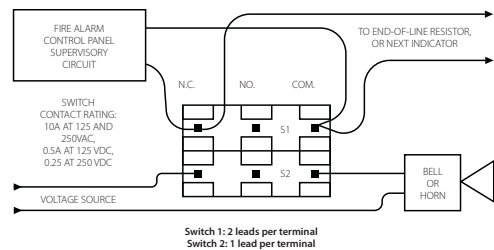
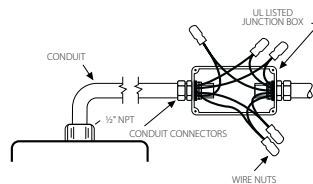

NOTE: The above diagram shows a connection between the common terminal (yellow – S1 and yellow-with-orange stripe – S2) and the normally closed terminal (blue – S1 and blue-with-orange stripe – S2). In this example, the indicator light and alarm will stay on until the valve is fully open. When the valve is fully open, the indicator light and alarm will go out. Cap off any unused wires (e.g. brown with orange stripe).

Only S1 (two leads per terminal) may be connected to the fire alarm control panel.

The connection of the alarm switch wiring shall be in accordance with NFPA 72 and the auxiliary switch per NFPA 70 (NEC).

FireLock® Check Valves



SERIES 717

Series 717 FireLock check valve is a CAD-developed design that is hydrodynamically efficient. A totally rubber encapsulated disc on 4 – 12”/100 – 300mm sizes provides superior corrosion resistance. This single disc design incorporates a spring assisted feature for non-slamming operation. For systems requiring a Riser Check option refer to section 10.09.

The 4”/100mm and larger sizes are provided with upstream and downstream drains and a welded-in nickel seat design. All sizes of Series 717 can be installed in the vertical or horizontal position to provide leak-free sealing under conditions as low as five feet of head. Each valve is factory tested to 500psi/3440kPa. The 2 1/2 and 3”/65 and 80mm sizes are UL/ULC Listed and 4”/100mm sizes and larger are UL/ULC Listed and FM Approved for services up to 250psi/1725kPa. Sizes 4 – 8”/100 – 200mm (except 165.1 mm size) are VdS approved.

Grooved ends allow fast, easy installation with just two Victaulic couplings or the valve may be mounted to flanged (ANSI CL.150) equipment using either to Victaulic Style 741 Vic-Flange® or Style 744 FireLock flange adapters on either end.



DIMENSIONS

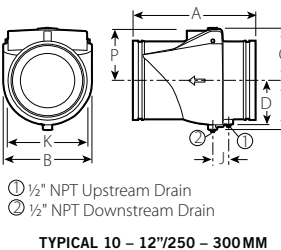
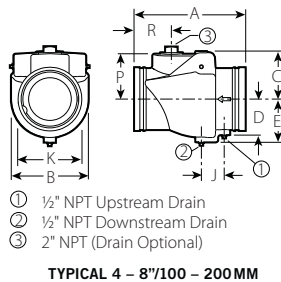
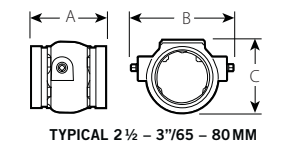

Size		Dimensions- Inches/millimeters										Approx. Wgt. Ea.
Nominal Size Inches/mm	Actual Outside Diameter Inches/mm	E to E A	B	C	D	E	J	K	P	R	Lbs. kg	
2 1/2 65	2.875 73.0	3.88 99	4.26 108	3.57 91	—	—	—	—	—	—	3.6 1.6	
76.1 mm	3.000 76.1	3.88 99	4.26 108	3.57 91	—	—	—	—	—	—	3.6 1.6	
3 80	3.500 88.9	4.25 108	5.06 129	4.17 106	—	—	—	—	—	—	4.5 2.0	
4 † 100	4.500 114.3	9.63 245	6.00 152	3.88 99	2.75 70	3.50 89	2.00 51	4.50 114	3.50 89	3.35 85	20.0 9.1	
5 † 125	5.563 141.3	10.50 267	6.80 173	4.50 114	—	4.17 106	2.15 55	5.88 149	4.08 104	3.98 101	27.0 12.3	
139.7 mm †	5.500 139.7	10.50 267	6.80 173	4.50 114	—	4.17 106	2.15 55	5.88 149	4.08 104	3.98 101	27.0 12.3	
6 † 150	6.625 168.3	11.50 292	8.00 203	5.00 127	—	4.50 114	2.38 61	6.67 169	4.73 120	3.89 99	38.0 17.2	
165.1 mm	6.500 165.1	11.50 292	8.00 203	5.00 127	—	4.50 114	2.38 61	6.67 169	4.73 120	3.89 99	38.0 17.2	
8 † 200	8.625 219.1	14.00 356	9.88 251	6.06 154	5.05 128	5.65 144	2.15 55	8.85 225	5.65 144	5.75 146	64.0 29.0	
10 250	10.750 273.0	17.00 432	12.00 305	7.09 180	5.96 151	6.69 170	2.15 55	10.92 277	6.73 171	—	100.0 45.4	
12 300	12.750 323.9	19.50 495	14.00 356	8.06 205	6.91 176	7.64 194	2.51 64	12.81 925	7.73 196	—	140.0 63.5	

† VdS Approved

JOB/OWNER

System No. _____
Location _____

CONTRACTOR

Submitted By _____
Date _____

ENGINEER

Spec Sect _____ Para _____
Approved _____
Date _____

WWW.VICTAULIC.COM

VICTAULIC IS A REGISTERED TRADEMARK OF VICTAULIC COMPANY. © 2007 VICTAULIC COMPANY. ALL RIGHTS RESERVED. PRINTED IN THE USA.

REV_H



10.08_1

FireLock® Check Valves

SERIES 717

MATERIAL SPECIFICATIONS

Body: Ductile iron conforming to ASTM A-536, grade 65-45-12. Ductile iron conforming to ASTM A-395, grade 65-45-15, is available upon special request. 2½ – 3"/65 – 80mm sizes PPS coated. 4 – 12"/100 – 300mm sizes painted black enamel.

Body Seat: 2½ – 3"/65 – 80mm sizes PPS coated. 4 – 12"/100 – 300mm integrally welded on nickel alloy.

Disc Seal or Coating:

- **Grade "E" EPDM**

EPDM (Green color code). Temperature range –30°F to +230°F/–34°C to +110°C.

Recommended for cold and hot water service within the specified temperature range plus a variety of dilute acids, oil-free air and many chemical services. UL classified in accordance with ANSI/NSF 61 for cold +86°F/+30°C and hot +180°F/+82°C potable water service. NOT RECOMMENDED FOR PETROLEUM SERVICES.

* Services listed are General Service Recommendations only. It should be noted that there are services for which these gaskets are not recommended. Reference should always be made to the latest Victaulic Gasket Selection Guide for specific gasket service recommendations and for a listing of services which are not recommended.

Discs:

- 2½ – 3"/65 – 80mm Aluminum bronze conforming to ASTM B-148 with Grade "E" Seal.
- 4 – 12"/100 – 300mm ductile iron conforming to ASTM A-536, grade 65-45-12, fully encapsulated in Grade "E" elastomer.

Shaft: 2½ – 3"/65 – 80mm Type 416 stainless steel. 4 – 12"/100 – 300mm Type 316 stainless steel.

Spring: All sizes Type 302/304 stainless steel.

Shaft Plug: 2½ – 3"/65 – 80mm only; SAE Hex Socket Type conforming to ASTM A-576, cadmium plated to military specifications QQ-P-416A, class 3 type 2. 4 – 12"/100 – 300mm only; carbon steel zinc plated to ASTM B-633.

Pipe Plug: 4 – 12"/100 – 300mm only; carbon steel zinc plated to ASTM B-633.

Provide Model 1000

Model 1011A



TEST AND DRAIN®

Sectional Floor Control Test and Drain Valve
for Systems Requiring Pressure Relief Valve



3/4" 1" 1 1/4" 1 1/2" 2"

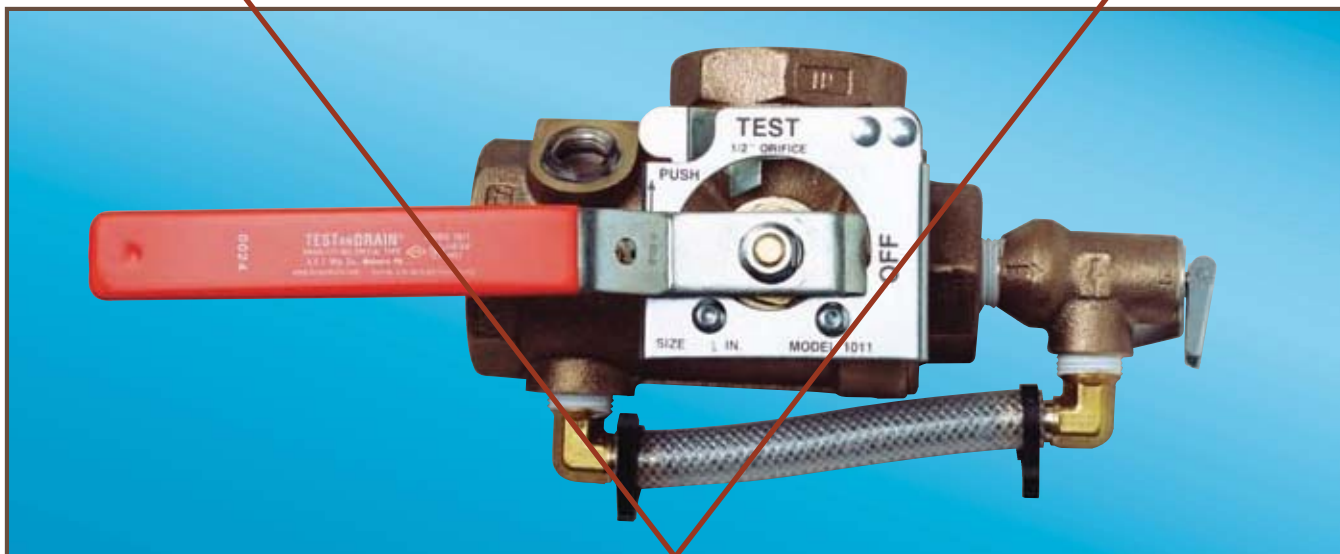

- The AGF Manufacturing Inc. **Model 1011A TEST AND DRAIN®** matches all the features and benefits of our **Model 1000** by providing both the test function and the express drain function in a multistory installation for a wet fire sprinkler system, with the added feature of an integral **Model 7000 Pressure Relief Valve** with drainage piping.
- The **Model 1011A** complies with the requirements of NFPA-13 that stipulate a pressure relief valve be installed on all gridded systems and downstream of all pressure reducing valves (see reverse).
- The **Model 1011A TEST AND DRAIN®** is a compact single handle ball valve which includes a tamper resistant test orifice and integral tamper resistant sight glasses, and is 300 PSI rated.
- Available in a full range of sizes from 3/4" to 2" NPT and BSPT, with all specifiable orifice sizes 3/8" (2.8K), 7/16" (4.2K), 1/2" (5.6K), 17/32" (8.0K), 5/8" (11.2K, ELO), 3/4" (14.0K, ESFR), and K25 as required by NFPA 13, 2007 Edition (see reverse).
- The included UL/FM **Model 7000 Pressure Relief Valve** features a flushing handle and is factory rated for 175 PSI. Other pressure settings are available and may be substituted.
- Designed to relieve excess system pressure caused by surges or temperature changes as well as solve the difficult problem of providing the relief valve with a convenient drainage-piping outlet.
- Shipped with relief valve and bypass drain ports plugged to expedite pressure testing the system.
- A locking kit is available and can be ordered with the valve to provide vandal resistance or prevent unintentional alarm activation.
- Repair kits including (1) adapter gasket, (1) ball, (2) valve seats, (1) stem packing, and (1) stem washer are available for all **TEST AND DRAIN®** valves. Valve and orifice size must be specified when ordering.

NOTE: It is important to note that the pressure rating of the relief valve indicates an operating range of pressure for both opening and closing of the valve. Standard relief valves are required to OPEN in a range of pressure between 90% and 105% of their rating. The valves are required to CLOSE at a pressure above 80% of that rating. The relief valve should be installed where it is easily accessible for maintenance. Care should be taken that the relief valve CANNOT be isolated from the system when the system is operational. A relief valve should NEVER have a shutoff valve or a plug downstream of its outlet.

Reliability, Versatility, Code Compatibility



TEST AND DRAIN®

Model 1011A

Model 1011A 300 PSI Bronze Ball Valve, Model 7000 Pressure Relief Valve
Factory Rated at 175 PSI with other settings available

DIMENSIONS

Orifice Size Available: 3/8", 7/16", 1/2", 17/32", ELO (5/8")*, ESFR (3/4")*, & K25**

SIZE	A	B	C	D	E	F	G	H
3/4"	7 9/16" (191 mm)	1 1/2" (37.5 mm)	2 3/16" (57 mm)	3 5/8" (93 mm)	3 3/8" (86 mm)	1 13/16" (46 mm)	4 9/16" (117 mm)	6 3/8" (162.5 mm)
1"	7 9/16" (191 mm)	1 1/2" (37.5 mm)	2 3/16" (57 mm)	3 5/8" (93 mm)	3 3/8" (86 mm)	1 13/16" (46 mm)	4 9/16" (117 mm)	6 3/8" (162.5 mm)
1 1/4"	7 15/16" (201 mm)	1 11/16" (43 mm)	2 9/16" (65 mm)	4 1/4" (108 mm)	3 5/8" (91 mm)	1 15/16" (51 mm)	5 9/16" (141 mm)	5 1/2" (139.7 mm)
1 1/2"	8 15/16" (227 mm)	1 13/16" (45 mm)	3 1/4" (81.5 mm)	5 1/16" (127 mm)	3 7/8" (99 mm)	2 5/8" (67 mm)	8 1/4" (207 mm)	10 7/8" (274 mm)
2"	8 15/16" (227 mm)	1 13/16" (45 mm)	3 1/4" (81.5 mm)	5 1/16" (127 mm)	3 7/8" (99 mm)	2 5/8" (67 mm)	8 1/4" (207 mm)	10 7/8" (274 mm)

* Available on 1 1/4" to 2" size units only ** Available on 1 1/2" and 2" size units only

THE MODEL 1011A PROVIDES ALL OF THE FOLLOWING...

From the 2007 Edition of NFPA 13

- Chapter 8.16.2.4.1* Provisions shall be made to properly drain all parts of the system.
- Chapter 8.16.2.4.2 Drain connections, interior sectional or floor control valve(s) –
- & 8.16.2.4.3 shall be provided with a drain connection having a minimum size as shown in Table 8.16.2.4.2.
- Chapter 8.16.2.4.4 Drains shall discharge outside or to a drain capable of handling the flow of the drain.
- Chapter A.8.17.4.2 (Wet Pipe System) test connection is permitted to terminate into a drain capable of accepting full flow... using an approved sight test connection containing a smooth bore corrosion-resistant orifice giving a flow equivalent to one sprinkler...
- Chapter 8.17.4.2.2 The test connection valve shall be readily accessible.
- Chapter 8.17.4.2.4 shall be permitted to be installed in any location... downstream of the waterflow alarm.
- Chapter 8.17.4.3.1 (Dry Pipe System) a trip test connection not less than 1" in diameter, terminating in a smooth bore corrosion-resistant orifice, to provide a flow equivalent to one sprinkler...
- Chapter 8.17.4.3.2 The trip test connection... with a shutoff valve and plug not less than 1", at least one of which shall be brass.
- Chapter 7.1.2 - a gridded wet pipe system shall be provided with a relief valve set to operate at 175 PSI or 10 PSI in excess of the maximum system pressure, whichever is greater.
- Chapter 8.16.1.2.3* A relief valve of not less than 1/2" in size shall be provided on the discharge side of the pressure-reducing valve set to operate at a pressure not exceeding 175 PSI.
- Chapter A.8.16.1.2.3 - consideration should be given to piping the discharge from the (pressure relief) valve

MODEL 1011A - FRONT VIEW

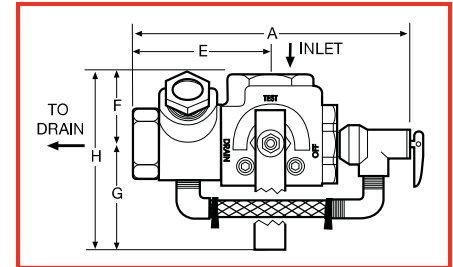

MODEL 1011A - PLAN VIEW

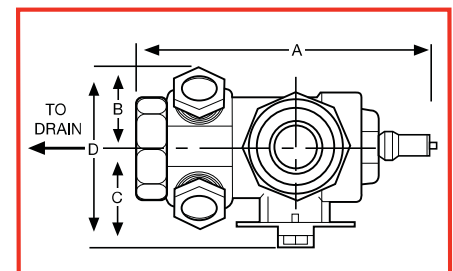

MATERIALS

- Handle: Steel
- Stem: Rod Brass
- Ball: C.P. Brass
- Body: Bronze
- Valve Seat: Impregnated Teflon®
- Indicator Plate: Steel
- Relief Valve: Bronze
- Bypass Fittings: Brass
- Bypass Tubing: Nylobraid

APPROVALS

- UL and ULC Listed: (EX4019 & EX4533)
- FM Approved
- NYC-BSA No. 720-87-SM



USA Patent # 4741361 and Other Patents Pending



AGF Manufacturing Inc.
100 Quaker Lane, Malvern, PA 19355
Phone: 610-240-4900
Fax: 610-240-4906
www.testandrain.com

Job Name: _____
Architect: _____
Engineer: _____
Contractor: _____



⚠ WARNING

- Installation must be performed by qualified personnel and in accordance with all national and local codes and ordinances.
- Shock hazard. Disconnect power source before servicing. Serious injury or death could result.
- Risk of explosion. Not for use in hazardous locations. Serious injury or death could result.

UL, CUL and CSFM Listed, FM Approved, LPCB Approved, For CE Marked (EN12259-5)/VdS Approved model use VSR-EU

Service Pressure: 450 PSI (31 BAR) - UL

Flow Sensitivity Range for Signal:

4-10 GPM (15-38 LPM) - UL

Maximum Surge: 18 FPS (5.5 m/s)

Contact Ratings: Two sets of SPDT (Form C)

10.0 Amps at 125/250VAC

2.0 Amps at 30VDC Resistive

10 mAmps min. at 24VDC

Conduit Entrances: Two knockouts provided for 1/2" conduit.

Individual switch compartments suitable for dissimilar voltages.

Environmental Specifications:

- NEMA 4/IP54 Rated Enclosure suitable for indoor or outdoor use with factory installed gasket and die-cast housing when used with appropriate conduit fitting.
- Temperature Range: 40°F - 120°F, (4.5°C - 49°C) - UL
- Non-corrosive sleeve factory installed in saddle.

Service Use:

Automatic Sprinkler	NFPA-13
One or two family dwelling	NFPA-13D
Residential occupancy up to four stories	NFPA-13R
National Fire Alarm Code	NFPA-72

Optional: Cover Tamper Switch Kit, Stock No. 0090148

General Information

The Model VSR is a vane type waterflow switch for use on wet sprinkler systems. It is UL Listed and FM Approved for use on steel pipe; schedules 10 through 40, sizes 2" thru 8" (50 mm thru 200 mm). LPC approved sizes are 2" thru 8" (50 mm thru 200 mm). See Ordering Information chart.

The VSR may also be used as a sectional waterflow detector on large systems.

The VSR contains two single pole, double throw, snap action switches and an adjustable, instantly recycling pneumatic retard. The switches are actuated when a flow of 10 GPM (38 LPM) or more occurs downstream of the device. The flow condition must exist for a period of time necessary to overcome the selected retard period.

Enclosure

The VSR switches and retard device are enclosed in a general purpose, die-cast housing. The cover is held in place with two tamper resistant screws which require a special key for removal. A field installable cover tamper switch is available as an option which may be used to indicate unauthorized removal of the cover. See bulletin number 5401103 for installation instructions of this switch.

Installation: See Fig. 1

These devices may be mounted on horizontal or vertical pipe. On horizontal pipe they should be installed on the top side of the pipe where they will be accessible. The device should not be installed within 6" (15 cm) of a fitting which changes the direction of the waterflow or within 24" (60 cm) of a valve or drain.

Drain the system and drill a hole in the pipe using a hole saw in a slow speed drill. (see Fig. 1)

Clean the inside pipe of all growth or other material for a distance equal to the pipe diameter on either side of the hole.

Roll the vane so that it may be inserted into the hole; do not bend or crease it. Insert the vane so that the arrow on the saddle points in the direction of the waterflow. Install the saddle strap and tighten nuts alternately to required torque. (see Fig. 1). The vane must not rub the inside of the pipe or bind in any way.

Specifications subject to change without notice.

Ordering Information			
Nominal Pipe Size	Model	Part Number	
2"	DN50	VSR-2	1144402
2 1/2"	DN65	VSR-2 1/2	1144425
3"	DN80	VSR-3	1144403
3 1/2"	-	VSR-3 1/2	1144435
4"	DN100	VSR-4	1144404
5"	-	VSR-5	1144405
6"	DN150	VSR-6	1144406
8"	DN200	VSR-8	1144408

Fig. 1

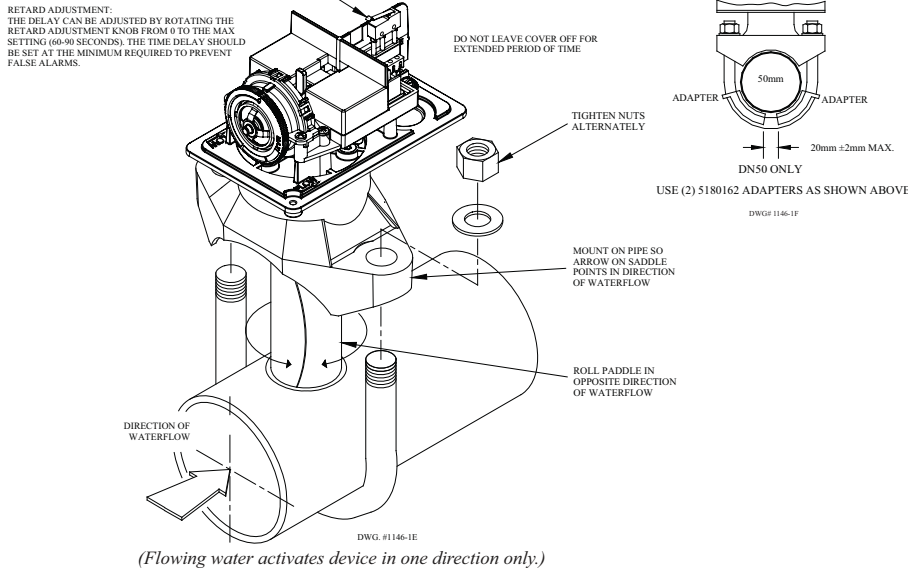
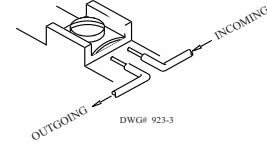

Fig. 2 Switch Terminal Connections
Clamping Plate Terminal



WARNING

An uninsulated section of a single conductor should not be looped around the terminal and serve as two separate connections. The wire must be severed, thereby providing supervision of the connection in the event that the wire become dislodged from under the terminal. Failure to sever the wire may render the device inoperable risking severe property damage and loss of life.

CAUTION

Waterflow switches that are monitoring wet pipe sprinkler systems should not be used as the sole initiating device to discharge AFFF, deluge, or chemical suppression systems. Waterflow switches used for this application may result in unintended discharges caused by surges, trapped air, or short retard times.

Installation Requirements

Model	Nominal Pipe Size		Nominal Pipe O.D.		Hole Size		U-Bolt Nuts Torque	
	inch	mm	inch	mm	inch	mm	ft-lb	n-m
VSR-2	2	DN50	2.375	60.3	1.25 + .125/-0.62	33.0 ± 2.0	20	27
VSR-2 1/2	2 1/2		2.875	73.0				
VSR-2 1/2	2 1/2	DN65	3.000	76.1				
VSR-3	3	DN80	3.500	88.9	2.00 ± .125	50.8 ± 2.0		
VSR-3 1/2	3 1/2		4.000	101.6				
VSR-4	4	DN100	4.500	114.3				
VSR-5	5		5.563	141.3				
VSR-6	6	DN150	6.625	168.3				
VSR-8	8	DN200	8.625	219.1				

Fig. 3 Typical Electrical Connections

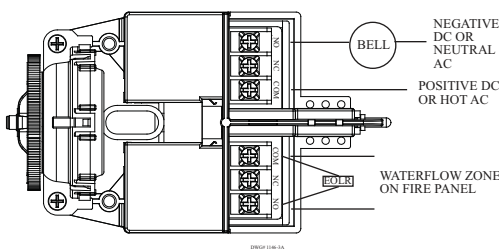

Notes:

1. The Model VSR has two switches, one can be used to operate a central station, proprietary or remote signaling unit, while the other contact is used to operate a local audible or visual annunciator.
2. A condition of LPC Approval of this product is that the electrical entry must be sealed to exclude moisture.
3. For supervised circuits see "Switch Terminal Connections" drawing and caution note (Fig. 2).

Fig. 4

Break out thin section of cover when wiring both switches from one conduit entrance.

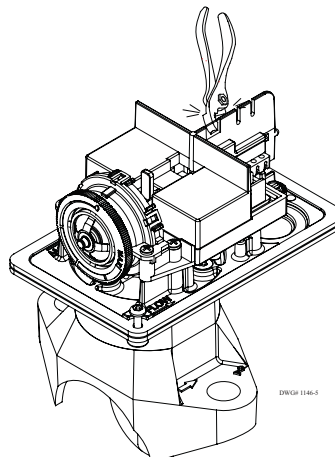
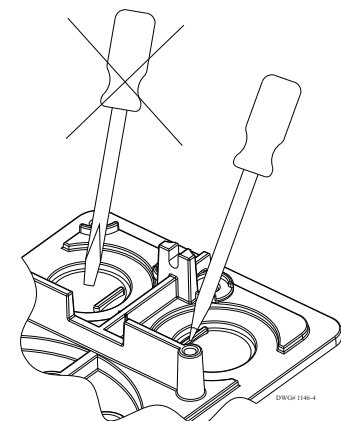

Fig. 5

To remove knockouts: Place screwdriver at inside edge of knockouts, not in the center.



Model	Nominal Pipe Size		Nominal Pipe O.D.		Compatible Pipe							
					Pipe Wall Thickness							
	inch	mm	inch	mm	Schedule 10 (UL)		Schedule 40 (UL)		BS-1387 (LPC)		DN (VDS)	
VSR-2	2	DN50	2.375	60.3	0.109	2.77	0.154	3.91	0.142	3.6	0.091	2.3
VSR-2 1/2	2 1/2		2.875	73.0	0.120	3.05	0.203	5.16				
VSR-2 1/2		DN65	3.000	76.1					0.142	3.6	0.102	2.6
VSR-3	3	DN80	3.500	88.9	0.120	3.05	0.216	5.49	0.157	4.0	0.114	2.9
VSR-3 1/2	3 1/2		4.000	101.6	0.120	3.05	0.226	5.74				
VSR-4	4	DN100	4.500	114.3	0.120	3.05	0.237	6.02	0.177	4.5	0.126	3.2
VSR-5	5		5.563	141.3	0.134	3.40	0.258	6.55				
VSR-6	6	DN150	6.625	168.3	0.134	3.40	0.280	7.11	0.197	5.0	0.157	4.0
VSR-8	8	DN200	8.625	219.1	0.148	3.76	0.322	8.18	0.248	6.3	0.177	4.5

Note: For copper or plastic pipe use Model VSR-CF.

Testing

The frequency of inspection and testing for the Model VSR and its associated protective monitoring system should be in accordance with applicable NFPA Codes and Standards and/or the authority having jurisdiction (manufacturer recommends quarterly or more frequently).

If provided, the inspector's test valve, that is usually located at the end of the most remote branch line, should always be used for test purposes. If there are no provisions for testing the operation of the flow detection device on the system, application of the VSR is not recommended or advisable. A minimum flow of 10 GPM (38 LPM) is required to activate this device.

Maintenance

Inspect detectors monthly for leaks. If leaks are found, replace the detector. The VSR waterflow switch should provide years of trouble-free service. The retard and switch assembly are easily field replaceable. In the unlikely event that either component does not perform properly, please order replacement retard switch assembly stock #1029055. There is no maintenance required, only periodic testing and inspection.

Removal

- To prevent accidental water damage, all control valves should be shut tight and the system completely drained before waterflow detectors are removed or replaced.
- Turn off electrical power to the detector, then disconnect wiring.
- Loosen nuts and remove U-bolts.
- Gently lift the saddle far enough to get your fingers under it. With your fingers, roll the vane so it will fit through the hole while continuing to lift the waterflow detector saddle.
- Lift detector clear of pipe.

Important Notice

Please advise the person responsible for testing of the fire protection system that this system must be tested in accordance with the testing instructions.

Mounting Dimensions

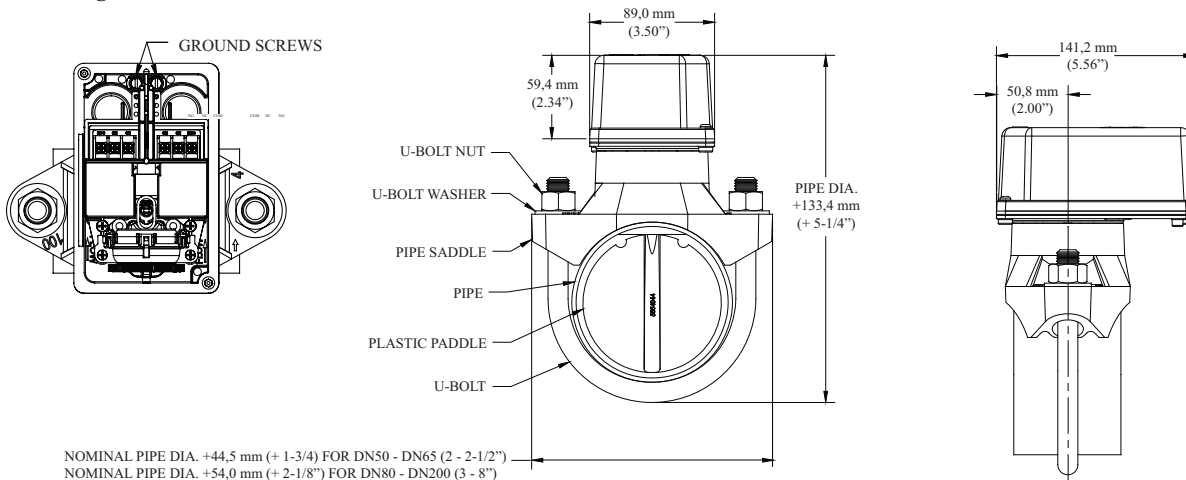

DWG# 1146-6

Series TY-FRB – 2.8, 4.2, 5.6, and 8.0 K-Factor Upright, Pendent, and Recessed Pendent Sprinklers Quick Response, Standard Coverage

General Description

The TYCO Series TY-FRB, 2.8, 4.2, 5.6, and 8.0 K-factor, Upright, Pendent, and Recessed Pendent Sprinklers described in this data sheet are quick response, standard coverage, decorative 3 mm glass bulb-type spray sprinklers designed for use in light or ordinary hazard, commercial occupancies such as banks, hotels, and shopping malls.

The recessed version of the Series TY-FRB Pendent Sprinkler, where applicable, is intended for use in areas with a finished ceiling. This recessed pendent sprinkler uses one of the following:

- A two-piece Style 10 (1/2 inch NPT) or Style 40 (3/4 inch NPT) Recessed Escutcheon with 1/2 inch (12,7 mm) of recessed adjustment or up to 3/4 inch (19,1 mm) of total adjustment from the flush pendent position, or a
- A two-piece Style 20 (1/2 inch NPT) or Style 30 (3/4 inch NPT) Recessed Escutcheon with 1/4 inch (6,4 mm) of recessed adjustment or up to 1/2 inch (12,7 mm) of total adjustment from the flush pendent position.

The adjustment provided by the Recessed Escutcheon reduces the accuracy to which the fixed pipe drops to the sprinklers must be cut.

Corrosion-resistant coatings, where applicable, are utilized to extend the life of copper alloy sprinklers beyond that which would otherwise be obtained when exposed to corrosive atmo-

spheres. Although corrosion-resistant coated sprinklers have passed the standard corrosion tests of the applicable approval agencies, the testing is not representative of all possible corrosive atmospheres. Consequently, it is recommended that the end user be consulted with respect to the suitability of these coatings for any given corrosive environment. The effects of ambient temperature, concentration of chemicals, and gas/chemical velocity, should be considered, as a minimum, along with the corrosive nature of the chemical to which the sprinklers will be exposed.

An intermediate level of the Series TY-FRB Pendent Sprinklers is detailed in Technical Data Sheet TFP356, and Sprinkler Guards are detailed in Technical Data Sheet TFP780.

NOTICE

The Series TY-FRB, 2.8, 4.2, 5.6, and 8.0 K-factor, Upright, Pendent, and Recessed Pendent Sprinklers described herein must be installed and maintained in compliance with this document and with the applicable standards of the National Fire Protection Association, in addition to the standards of any authorities having jurisdiction. Failure to do so may impair the performance of these devices.

The owner is responsible for maintaining their fire protection system and devices in proper operating condition. The installing contractor or sprinkler manufacturer should be contacted with any questions.

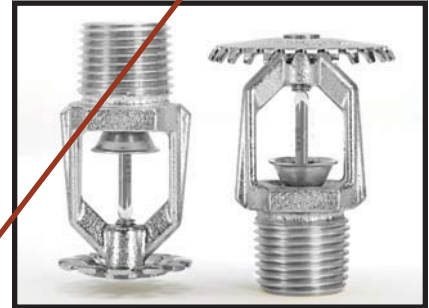

Sprinkler Identification Number (SIN)

TY1131:	Upright	2.8K, 1/2" NPT
TY1231:	Pendent	2.8K, 1/2" NPT
TY2131:	Upright	4.2K, 1/2" NPT
TY2231:	Pendent	4.2K, 1/2" NPT
TY3131:	Upright	5.6K, 1/2" NPT
TY3231:	Pendent	5.6K, 1/2" NPT
TY4131:	Upright	8.0K, 3/4" NPT
TY4231:	Pendent	8.0K, 3/4" NPT
TY4831:	Upright	8.0K, 1/2" NPT
TY4931:	Pendent	8.0K, 1/2" NPT

IMPORTANT

Always refer to Technical Data Sheet TFP700 for the "INSTALLER WARNING" that provides cautions with respect to handling and installation of sprinkler systems and components. Improper handling and installation can permanently damage a sprinkler system or its components and cause the sprinkler to fail to operate in a fire situation or cause it to operate prematurely.

SPRINKLERS SHALL BE WHITE CONCEALED IN FINISHED SPACES IN ACCORDANCE WITH CONTRACT DOCUMENT SPECIFICATIONS.

* Temperature rating is indicated on Deflector.

** Pipe thread connections per ISO 7-1 can be provided on special request.

- 1 - Frame
- 2 - Button
- 3 - Sealing Assembly
- 4 - Bulb
- 5 - Compression Screw
- 6 - Deflector*

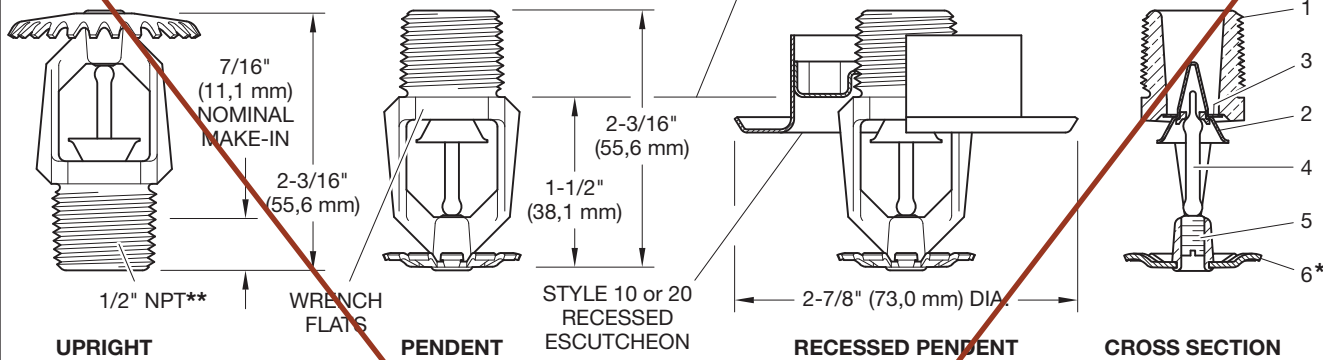

FIGURE 3
QUICK RESPONSE SERIES TY-FRB UPRIGHT (TY3131) AND PENDENT (TY3231) SPRINKLERS
5.6 K-FACTOR, 1/2 INCH NPT

* Temperature rating is indicated on Deflector.

** Pipe thread connections per ISO 7-1 can be provided on special request.

- 1 - Frame
- 2 - Button
- 3 - Sealing Assembly
- 4 - Bulb
- 5 - Compression Screw
- 6 - Deflector*

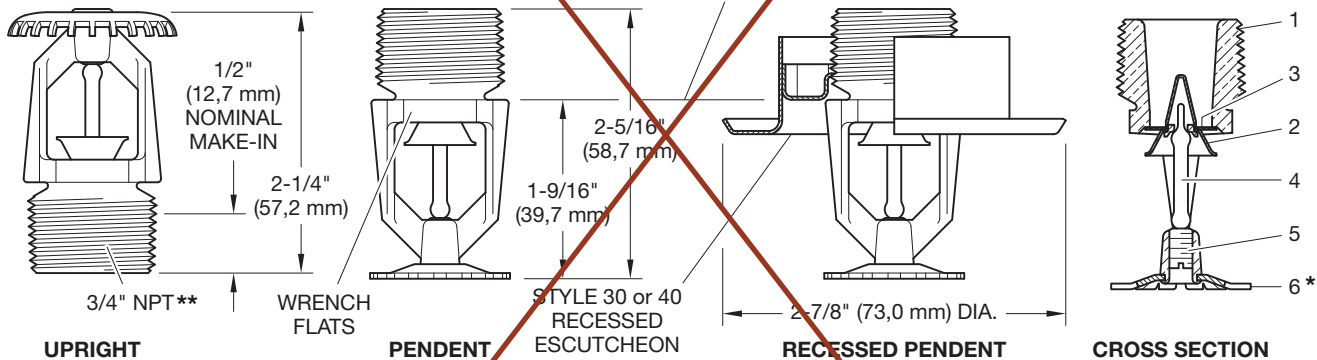
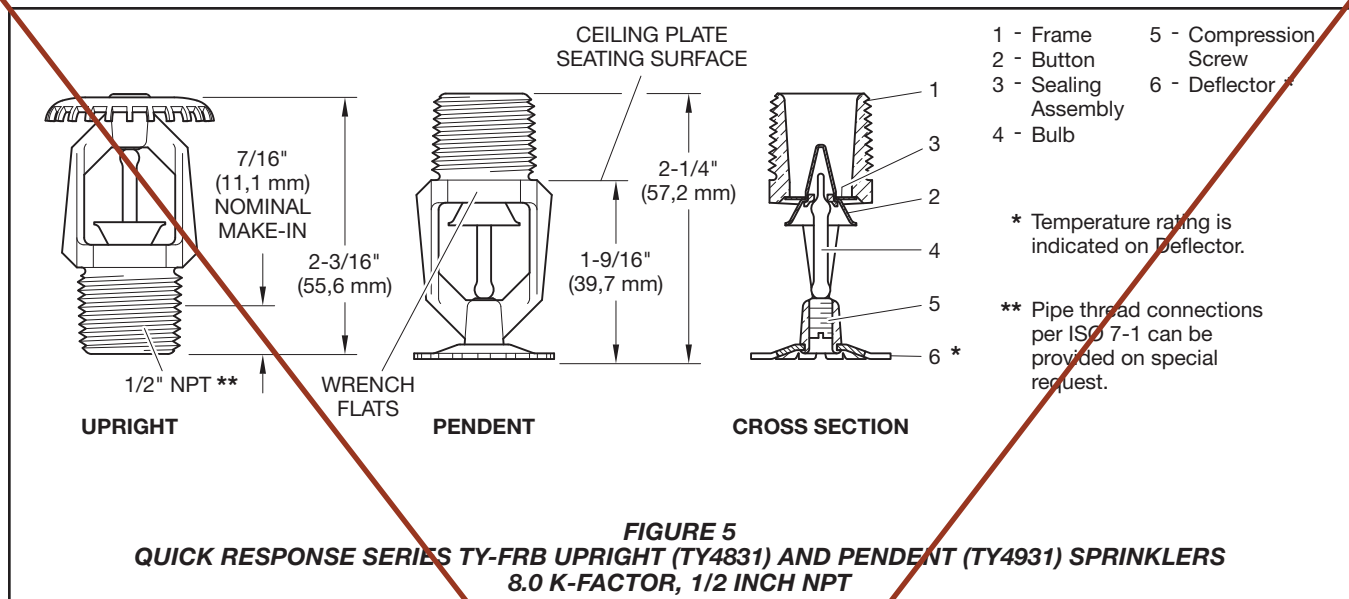

FIGURE 4
QUICK RESPONSE SERIES TY-FRB UPRIGHT (TY4131) AND PENDENT (TY4231) SPRINKLERS
8.0 K-FACTOR, 3/4 INCH NPT

SPRINKLERS SHALL BE WHITE CONCEALED IN FINISHED SPACES IN ACCORDANCE WITH CONTRACT DOCUMENT SPECIFICATIONS.



Technical Data

Approvals

UL and C-UL Listed
FM, LPCB, and NYC Approved
Refer to Table A and B for complete approval information including corrosion-resistant status.

Maximum Working Pressure

Refer to Table C.

Discharge Coefficient

K=2.8 GPM/psi^{1/2} (40,3 LPM/bar^{1/2})
K=4.2 GPM/psi^{1/2} (60,5 LPM/bar^{1/2})
K=5.6 GPM/psi^{1/2} (80,6 LPM/bar^{1/2})
K=8.0 GPM/psi^{1/2} (115,2 LPM/bar^{1/2})

Temperature Rating

Refer to Table A and B.

Finishes

Sprinkler: Refer to Table D. Recessed Escutcheon: White Coated, Chrome Plated, or Brass Plated.

Physical Characteristics

Frame Bronze
Button Brass/Copper
Sealing Assembly Beryllium Nickel w/TEFLON
Bulb Glass
Compression Screw Bronze
Deflector Copper/Bronze
Bushing (K=2.8) Bronze

Operation

The glass bulb contains a fluid that expands when exposed to heat. When the rated temperature is reached, the fluid expands sufficiently to shatter the glass bulb, allowing the sprinkler to activate and water to flow.

Design Criteria

The TYCO Series TY-FRB, 2.8, 4.2, 5.6, and 8.0 K-factor, Upright, Pendent, and Recessed Pendent Sprinklers are intended for fire protection systems designed in accordance with the standard installation rules recognized by the applicable Listing or Approval agency (such as, UL Listing is based on the requirements of NFPA 13, and FM Approval is based on the requirements of FM's Loss Prevention Data Sheets). Only the Style 10, 20, 30, or 40 Recessed Escutcheon, as applicable, is to be used for recessed pendent installations.

Installation

The TYCO Series TY-FRB, 2.8, 4.2, 5.6, and 8.0 K-factor, Upright, Pendent, and Recessed Pendent Sprinklers must be installed in accordance with this section.

General Instructions

Do not install any bulb-type sprinkler if the bulb is cracked or there is a loss of liquid from the bulb. With the sprinkler held horizontally, a small air bubble should be present. The diameter of the air bubble is approximately 1/16 inch (1,6 mm) for the 135°F (57°C) and 3/32 inch (2,4 mm) for the 286°F (141°C) temperature ratings.

A leak-tight 1/2 inch NPT sprinkler joint should be obtained by applying a minimum to maximum torque of 7 to 14 ft.-lbs. (9,5 to 19,0 Nm). A leak tight 3/4 inch NPT sprinkler joint should be obtained with a torque of 10 to 20 ft.-lbs. (13,4 to 26,8 Nm). Higher levels of

torque can distort the sprinkler Inlet with consequent leakage or impairment of the sprinkler.

Do not attempt to compensate for insufficient adjustment in the Escutcheon Plate by under- or over-tightening the sprinkler. Re-adjust the position of the sprinkler fitting to suit.

Series TY-FRB Upright and Pendent Sprinklers

The Series TY-FRB Pendent and Upright Sprinklers must be installed in accordance with the following instructions.

Step 1. Install Pendent sprinklers in the pendent position. Install upright sprinklers in the upright position.

Step 2. With pipe-thread sealant applied to the pipe threads, hand-tighten the sprinkler into the sprinkler fitting.

Step 3. Tighten the sprinkler into the sprinkler fitting using only the W-Type 6 Sprinkler Wrench (Figure 14). With reference to Figures 1 through 5, apply the W-Type 6 Sprinkler Wrench to the sprinkler wrench flats.

Series TY-FRB Recessed Pendent Sprinklers

The Series TY-FRB Recessed Pendent Sprinklers must be installed in accordance with the following instructions.

Step A. After installing the Style 10, 20, 30, or 40 Mounting Plate, as applicable, over the sprinkler threads and with pipe-thread sealant applied to the pipe threads, hand-tighten the sprinkler into the sprinkler fitting.

Step B. Tighten the sprinkler into the sprinkler fitting using only the W-Type 7 Recessed Sprinkler Wrench (Figure

K FACTOR	TYPE	TEMPERATURE	BULB LIQUID COLOR	SPRINKLER FINISH (See Note 8)			
				NATURAL BRASS	CHROME PLATED	SIGNAL*** WHITE	LEAD COATED
5.6 1/2" NPT	PENDENT (TY3231) and UPRIGHT (TY3131)	135°F (57°C)	Orange	1, 2, 3, 4, 5, 6, 7			1, 2, 3, 5
		155°F (68°C)	Red				
		175°F (79°C)	Yellow				
		200°F (93°C)	Green				
		286°F (141°C)	Blue				
	RECESSED PENDENT (TY3231) Figure 10	135°F (57°C)	Orange	1, 2, 4, 5			N/A
		155°F (68°C)	Red				
		175°F (79°C)	Yellow				
		200°F (93°C)	Green				
	RECESSED PENDENT (TY3231)** Figure 11	135°F (57°C)	Orange	1, 2, 3, 4, 5			N/A
		155°F (68°C)	Red				
		175°F (79°C)	Yellow				
200°F (93°C)		Green					
8.0 3/4" NPT	PENDENT (TY4231) and UPRIGHT (TY4131)	135°F (57°C)	Orange	1, 2, 3, 4, 5, 6, 7			1, 2, 5
		155°F (68°C)	Red				
		175°F (79°C)	Yellow				
		200°F (93°C)	Green				
		286°F (141°C)	Blue				
	RECESSED PENDENT (TY4231)* Figure 12	135°F (57°C)	Orange	1, 2, 5			N/A
		155°F (68°C)	Red				
		175°F (79°C)	Yellow				
		200°F (93°C)	Green				
	RECESSED PENDENT (TY4231)** Figure 13	135°F (57°C)	Orange	1, 2, 3, 5			N/A
		155°F (68°C)	Red				
		175°F (79°C)	Yellow				
200°F (93°C)		Green					
8.0 1/2" NPT	PENDENT (TY4931) and UPRIGHT (TY4831)	135°F (57°C)	Orange	1, 2, 4, 5, 6			1, 2, 5
		155°F (68°C)	Red				
		175°F (79°C)	Yellow				
		200°F (93°C)	Green				
		286°F (141°C)	Blue				

NOTES:

1. Listed by Underwriters Laboratories, Inc., (UL) as Quick Response Sprinklers.
2. Listed by Underwriters Laboratories, Inc., for use in Canada (C-UL) as Quick Response Sprinklers.
3. Approved by Factory Mutual Research Corporation (FM) as Quick Response Sprinklers.
4. Approved by the Loss Prevention Certification Board (LPCB Ref. No. 007k/04) as Quick Response Sprinklers. However, LPCB does not rate the thermal sensitivity of recessed sprinklers.
5. Approved by the City of New York under MEA 354-01-E.
6. VdS Approved (For details, contact Tyco Fire Suppression & Building Products, Enschede, Netherlands, Tel. 31-53-428-4444/Fax 31-53-428-3377.)
7. Approved by the Loss Prevention Certification Board (LPCB Ref. No. 094a/06) as Quick Response Sprinklers.
8. Where Polyester Coated and Lead-Coated Sprinklers are noted to be UL and C-UL Listed, the sprinklers are UL and C-UL Listed as Corrosion-Resistant Sprinklers. Where Lead-Coated Sprinklers are noted to be FM Approved, the sprinklers are FM Approved as a Corrosion Resistant Sprinklers.

* Installed with Style 10 (1/2" NPT) or Style 40 (3/4" NPT) 3/4" Total Adjustment Recessed Escutcheon, as applicable.

** Installed with Style 20 (1/2" NPT) or Style 30 (3/4" NPT) 1/2" Total Adjustment Recessed Escutcheon, as applicable.

*** Frame and Deflector only. Listings and approvals apply to color (Special Order).

N/A: Not Available

TABLE B
LABORATORY LISTINGS AND APPROVALS FOR
5.6 AND 8.0 K-FACTOR SPRINKLERS

K FACTOR	TYPE	SPRINKLER FINISH			
		NATURAL BRASS	CHROME PLATED	SIGNAL WHITE	LEAD COATED
2.8 1/2" NPT	PENDENT (TY1231) and UPRIGHT (TY1131)	175 PSI (12,1 BAR)			N/A
	RECESSED PENDENT (TY1231)				
4.2 1/2" NPT	PENDENT (TY2231) and UPRIGHT (TY2131)	175 PSI (12,1 BAR)			N/A
	RECESSED PENDENT (TY2231)				
5.6 1/2" NPT	PENDENT (TY3231) and UPRIGHT (TY3131)	250 PSI (17,2 BAR) OR 175 PSI (12,1 BAR) (SEE NOTE 1)			175 PSI (12,1 BAR)
	RECESSED PENDENT (TY3231)				N/A
8.0 3/4" NPT	PENDENT (TY4231) and UPRIGHT (TY4131)	175 PSI (12,1 BAR)			175 PSI (12,1 BAR)
	RECESSED PENDENT (TY4231)				N/A
8.0 1/2" NPT	PENDENT (TY4931) and UPRIGHT (TY4831)	175 PSI (12,1 BAR)			175 PSI (12,1 BAR)

NOTES:

1. The maximum working pressure of 250 psi (17,2 bar) only applies to the Listing by Underwriters Laboratories Inc. (UL); the Listing by Underwriters Laboratories, Inc. for use in Canada (C-UL); and, the Approval by the City of New York.

TABLE C
MAXIMUM WORKING PRESSURE

Care and Maintenance

The TYCO Series TY-FRB must be maintained and serviced in accordance with this section.

Before closing a fire protection system main control valve for maintenance work on the fire protection system that it controls, obtain permission to shut down the affected fire protection systems from the proper authorities and notify all personnel who may be affected by this action.

Absence of the outer piece of an escutcheon, which is used to cover a clearance hole, can delay sprinkler operation in a fire situation.

Sprinklers which are found to be leaking or exhibiting visible signs of corrosion must be replaced.

Automatic sprinklers must never be painted, plated, coated, or otherwise altered after leaving the factory. Modified sprinklers must be replaced. Sprinklers that have been exposed to

corrosive products of combustion, but have not operated, should be replaced if they cannot be completely cleaned by wiping the sprinkler with a cloth or by brushing it with a soft bristle brush.

Care must be exercised to avoid damage to the sprinklers - before, during, and after installation. Sprinklers damaged by dropping, striking, wrench twist/slippage, or the like, must be replaced. Also, replace any sprinkler that has a cracked bulb or that has lost liquid from its bulb. (Ref. Installation Section.)

The owner is responsible for the inspection, testing, and maintenance of their fire protection system and devices in compliance with this document, as well as with the applicable standards of the National Fire Protection Association (e.g., NFPA 25), in addition to the standards of any other authorities having jurisdiction. Contact the installing contractor or sprinkler manufacturer regarding any questions.

Automatic sprinkler systems are recommended to be inspected, tested, and maintained by a qualified Inspec-

tion Service in accordance with local requirements and/or national codes.

Care must be exercised to avoid damage to the sprinklers -before, during, and after installation. Sprinklers damaged by dropping, striking, wrench twist/slippage, or the like, must be replaced. Also, replace any sprinkler that has a cracked bulb or that has lost liquid from its bulb. (Ref. Installation Section).

Initial and frequent visual inspections of random samples are recommended for corrosion-resistant sprinklers to verify the integrity of the corrosion-resistant material of construction. Thereafter, annual inspections per NFPA 25 should suffice.

Inspections of corrosion-resistant sprinklers are recommended at close range, instead of from the floor level per NFPA. Inspection at close range can better determine the exact sprinkler condition and the long-term integrity of the corrosion-resistant material, which can be affected by the corrosive conditions present.

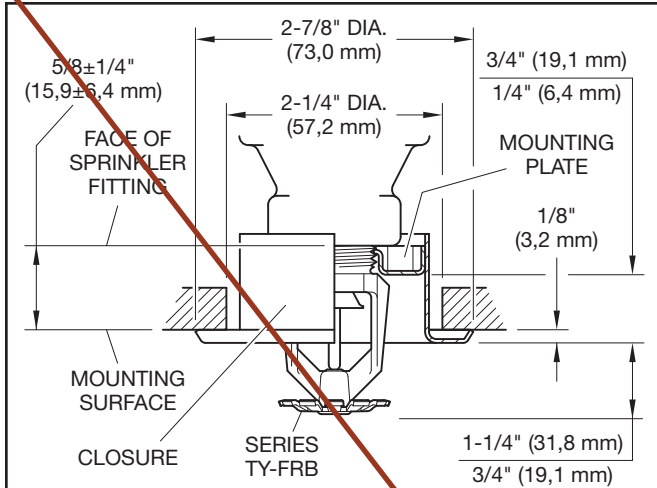

FIGURE 10
SERIES TY-FRB RECESSED PENDENT
WITH TWO-PIECE 3/4 INCH TOTAL ADJUSTMENT
STYLE 10 RECESSED ESCUTCHEON
5.6 K-FACTOR, 1/2 INCH NPT

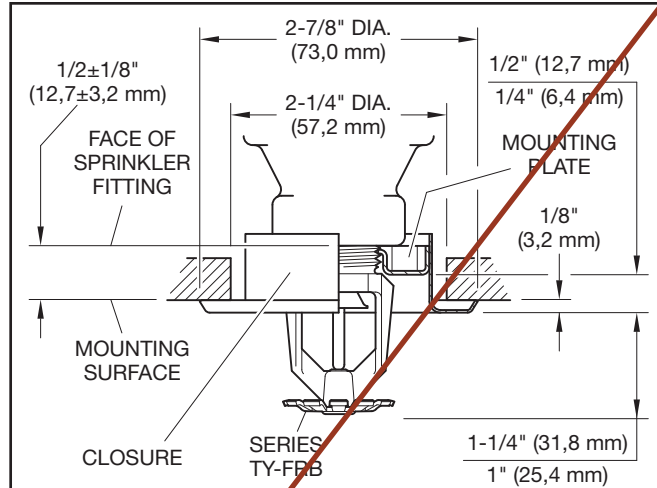

FIGURE 11
SERIES TY-FRB RECESSED PENDENT
WITH TWO-PIECE 1/2 INCH TOTAL ADJUSTMENT
STYLE 20 RECESSED ESCUTCHEON
5.5 K-FACTOR, 1/2 INCH NPT

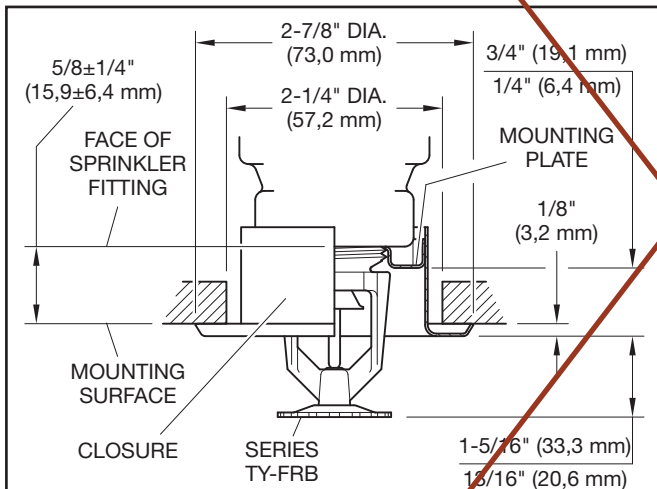

FIGURE 12
SERIES TY-FRB RECESSED PENDENT
WITH TWO-PIECE 3/4 INCH TOTAL ADJUSTMENT
STYLE 40 RECESSED ESCUTCHEON
8.0 K-FACTOR, 3/4 INCH NPT

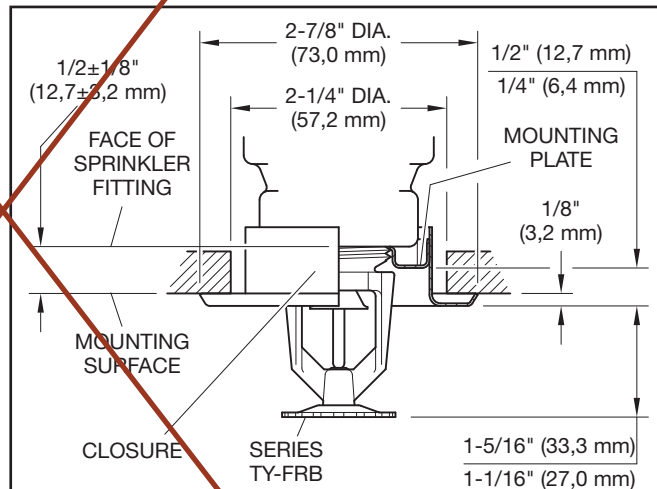

FIGURE 13
SERIES TY-FRB RECESSED PENDENT
WITH TWO-PIECE 1/2 INCH TOTAL ADJUSTMENT
STYLE 30 RECESSED ESCUTCHEON
8.0 K-FACTOR, 3/4 INCH NPT

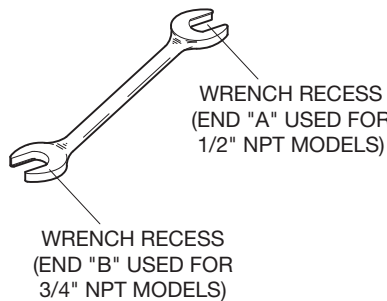

FIGURE 14
W-TYPE 6 SPRINKLER
WRENCH

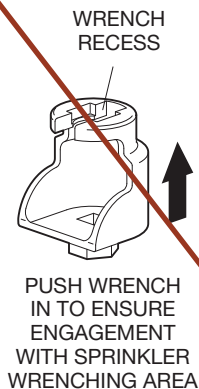

FIGURE 15
W-TYPE 7 RECESSED
SPRINKLER WRENCH

Series EC-11 and EC-14 Sprinklers, 11.2 K and 14.0 K Upright, and Pendent Extended Coverage Light and Ordinary Hazard

General Description

TYCO Series EC-11 and EC-14 Extended Coverage Upright and Pendent Sprinklers are decorative glass-bulb sprinklers designed for use in light or ordinary hazard occupancies. They are intended for use in automatic sprinkler systems designed in accordance with standard installation rules (e.g., NFPA 13) for a maximum coverage area of 400 ft² (37,2 m²), as compared to the maximum coverage area of 130 ft² (12,1 m²) for standard coverage sprinklers used in ordinary hazard occupancies or 225 ft² (20,6 m²) for standard coverage sprinklers used in light hazard occupancies.

Series EC-11 and EC-14 Sprinklers feature a UL and C-UL Listing that permits their use with unobstructed or non-combustible obstructed ceiling construction as defined and permitted by NFPA 13, as well as a specific application listing for use under concrete tees.

Series EC-11 and EC-14 Extended Coverage Sprinklers have been fire tested to compare their performance to that of standard coverage spray sprinklers. These tests have shown that the protection provided is equal to or more effective than standard coverage spray sprinklers.

Corrosion-resistant coatings, where applicable, help extend the life of copper alloy sprinklers beyond that which occurs when exposed to corrosive atmospheres. Although corrosion-resistant coated sprinklers passed standard corrosion tests of the applicable approval agencies, this testing is not representative of all possible corrosive atmospheres. Consequently, it is recommended that the end user be consulted with respect to the suitability of these corrosion-resistant coatings for any given corrosive environment. The effects of ambient temperature, concentration of chemicals, and gas/chemical velocity should be considered, along with the corrosive nature of the chemical to which the sprinklers will be exposed.

NOTICE

Series EC-11 and EC-14 Extended Coverage Sprinklers described herein must be installed and maintained in compliance with this document, as well as with the applicable standards of the National Fire Protection Association, in addition to the standards of any other authorities having jurisdiction. Failure to do so may impair the performance of these devices.

The owners is responsible for maintaining their fire protection system and devices in proper operating condition. The installing contractor or sprinkler manufacturer should be contacted with any questions.

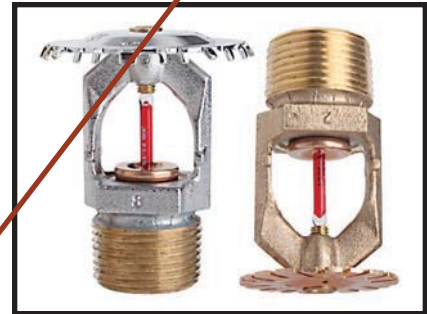

Sprinkler Identification Numbers (SINs)

TY5137 - Upright, 11.2K

TY5237 - Pendent, 11.2K

TY6137 - Upright, 14.0K

TY6237 - Pendent, 14.0K

TY5137 is a redesignation for C5137, G1894, and S2510.

TY5237 is a redesignation for C5237, G1893, and S2511.

TY6137 is a redesignation for C6137, G1896, and S2610.

TY6237 is a redesignation for C6237, G1895, and S2611.

IMPORTANT

Always refer to Technical Data Sheet TFP700 for the "INSTALLER WARNING" that provides cautions with respect to handling and installation of sprinkler systems and components. Improper handling and installation can permanently damage a sprinkler system or its components and cause the sprinkler to fail to operate in a fire situation or cause it to operate prematurely.

**SPRINKLERS SHALL BE WHITE CONCEALED
IN FINISHED SPACES IN ACCORDANCE WITH
CONTRACT DOCUMENT SPECIFICATIONS.**

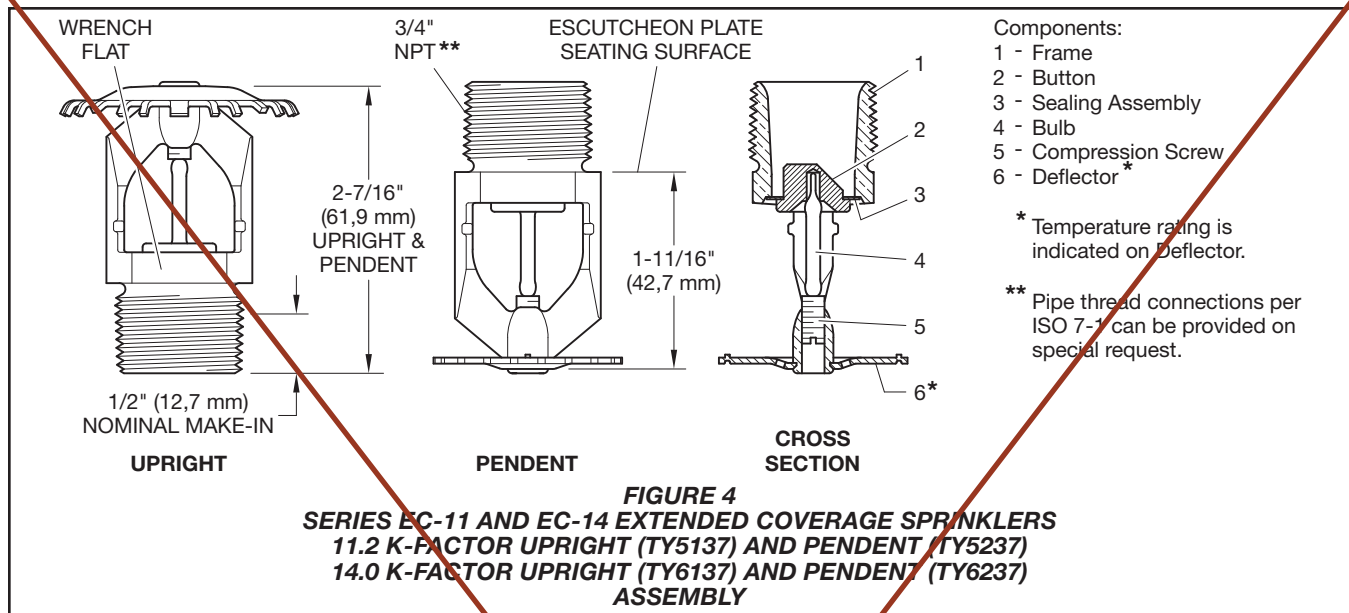

Hazard	Type	Temperature	Bulb Liquid	Sprinkler Finish (See Note 5)			
				Natural Brass	Chrome Plated	White* Polyester	Lead Coated
Light Table B describes UL and C-UL Sensitivity Rating Table C describes FM Sensitivity Rating	Upright K=11.2 (TY5137) Pendent K=11.2 (TY5237) K=14.0 (TY6237)	135°F (57°C)	Orange	1, 2, 3**, 4			
		155°F (68°C)	Red				
		175°F (79°C)	Yellow				
		200°F (93°C)	Green	1, 2, 4	1, 2, 4		
	Recessed Pendent K=11.2 (TY5237) K=14.0 (TY6237) With Style 30 Escutcheon	286°F (141°C)	Blue				
		135°F (57°C)	Orange				
		155°F (68°C)	Red	1, 2, 3, 4			
		175°F (79°C)	Yellow				
Ordinary Table B describes UL and C-UL Sensitivity Rating Table C describes FM Sensitivity Rating	Upright K=11.2 (TY5137) K=14.0 (TY6137) Pendent K=11.2 (TY5237) K=14.0 (TY6237)	200°F (93°C)	Green				
		286°F (141°C)	Blue				
		135°F (57°C)	Orange				
		155°F (68°C)	Red	1, 2, 3, 4			
	Recessed Pendent K=11.2 (TY5237) K=14.0 (TY6237) With Style 40 Escutcheon	175°F (79°C)	Yellow				
		200°F (93°C)	Green	1, 2, 3, 4			
		286°F (141°C)	Blue				
		135°F (57°C)	Orange				
	155°F (68°C)	Red	1, 2, 4				
	175°F (79°C)	Yellow					
	200°F (93°C)	Green					
	286°F (141°C)	Blue					

Notes

(1). Listed by Underwriters Laboratories, Inc. (UL)

(2). Listed by Underwriters Laboratories, Inc. for use in Canada (C-UL)

(3). Approved by Factory Mutual Research Corporation (FM)

(4). Approved by the City of New York under MEA 177-03-E

(5). Where Polyester Coated or Lead Coated Sprinklers are noted to be UL and C-UL Listed, the sprinklers are UL and C-UL Listed as Corrosion Resistant Sprinklers

* Frame and Deflector only. Listings and approvals apply to color (Special Order)

** Pendent Only

N/A: Not Available

TABLE A
LABORATORY LISTINGS AND APPROVALS

SPRINKLERS SHALL BE WHITE CONCEALED IN FINISHED SPACES IN ACCORDANCE WITH CONTRACT DOCUMENT SPECIFICATIONS.

Area	Style	Light Hazard					Ordinary Hazard				
		135°F (57°C)	155°F (68°C)	175°F (79°C)	200°F (93°C)	286°F (141°C)	135°F (57°C)	155°F (68°C)	175°F (79°C)	200°F (93°C)	286°F (141°C)
14 x 14	Upright or Pendent	-	-	-	-	-	QR	QR	QR	QR	QR
	Style 30 Recessed	-	-	-	-	-	QR	QR	QR	QR	QR
	Style 40 Recessed	-	-	-	-	-	QR	QR	QR	QR	QR
16 x 16	Upright or Pendent	QR*	QR*	QR*	QR*	QR*	SR	SR	SR	SR	SR
	Style 30 Recessed	QR*	QR*	QR*	QR*	QR*	SR	SR	SR	SR	SR
	Style 40 Recessed	N/A	N/A	N/A	N/A	N/A	SR	SR	SR	SR	SR
18 x 18	Upright or Pendent	QR*	QR*	QR*	QR*	QR*	SR	SR	SR	SR	SR
	Style 30 Recessed	QR*	QR*	QR*	QR*	QR*	SR	SR	SR	SR	SR
	Style 40 Recessed	N/A	N/A	N/A	N/A	N/A	SR	SR	SR	SR	SR
20 x 20	Upright or Pendent	QR*	QR*	QR*	SR*	SR*	SR	SR	SR	SR	SR
	Style 30 Recessed	QR*	QR*	QR*	SR*	SR*	SR	SR	SR	SR	SR
	Style 40 Recessed	N/A	N/A	N/A	N/A	N/A	SR	SR	SR	SR	SR

QR: Quick Response
 SR: Standard Response
 N/A: Not Applicable
 * Does not apply to Upright K=14.0

TABLE B
SENSITIVITY RATING FOR UL AND C-UL LISTING OF SERIES EC-11 OR EC-14 SPRINKLERS
 (Refer to Table D for Permitted K-Factor/Area Combinations)

Area	Style	Light Hazard					Ordinary Hazard				
		135°F (57°C)	155°F (68°C)	175°F (79°C)	200°F (93°C)	286°F (141°C)	135°F (57°C)	155°F (68°C)	175°F (79°C)	200°F (93°C)	286°F (141°C)
14 x 14	Upright or Pendent	-	-	-	-	-	SR	SR	SR	SR	SR
	Style 30 Recessed	-	-	-	-	-	N/A	N/A	N/A	N/A	N/A
	Style 40 Recessed	-	-	-	-	-	N/A	N/A	N/A	N/A	N/A
16 x 16	Upright or Pendent	QR*	QR*	N/A	N/A	N/A	SR	SR	SR	SR	SR
	Style 30 Recessed	QR*	QR*	N/A	N/A	N/A	N/A	N/A	N/A	N/A	N/A
	Style 40 Recessed	N/A	N/A	N/A	N/A	N/A	N/A	N/A	N/A	N/A	N/A
18 x 18	Upright or Pendent	QR*	QR*	N/A	N/A	N/A	SR	SR	SR	SR	SR
	Style 30 Recessed	QR	QR	N/A	N/A	N/A	N/A	N/A	N/A	N/A	N/A
	Style 40 Recessed	N/A	N/A	N/A	N/A	N/A	N/A	N/A	N/A	N/A	N/A
20 x 20	Upright or Pendent	QR*	QR*	N/A	N/A	N/A	SR	SR	SR	SR	SR
	Style 30 Recessed	QR	QR	N/A	N/A	N/A	N/A	N/A	N/A	N/A	N/A
	Style 40 Recessed	N/A	N/A	N/A	N/A	N/A	N/A	N/A	N/A	N/A	N/A

QR: Quick Response
 SR: Standard Response
 N/A: Not Applicable
 * Does not apply to Upright K=14.0

TABLE C
SENSITIVITY RATING FOR FM APPROVAL OF SERIES EC-11 OR EC-14 SPRINKLERS
 (NOTE: REFER TO FM LOSS PREVENTION DATA SHEET 2-8N FOR PERMITTED K-FACTOR/AREA COMBINATIONS)

**SPRINKLERS SHALL BE WHITE CONCEALED
 IN FINISHED SPACES IN ACCORDANCE WITH
 CONTRACT DOCUMENT SPECIFICATIONS.**

Technical Data

Approvals

TYCO Series EC-11 and EC-14 Extended Coverage Upright, Pendent, and Recessed Pendent Sprinklers are UL and C-UL Listed. Refer to Table A for complete sprinkler approval information including corrosion-resistant status. The approvals apply to the service conditions indicated in the Design Criteria section.

Series EC-11 and EC-14 Extended Coverage Upright and Pendent Sprinklers are FM Approved. Refer to Table A for complete sprinkler approval information including corrosion-resistant status. The approvals apply to the service conditions indicated in the Design Criteria section.

The Style 60 Two-Piece Flush Escutcheon (Figure 4) is UL Listed and FM Approved for use with the Series EC-11 and EC-14 Pendent Sprinklers.

Maximum Working Pressure
175 psi (12,1 bar)

Pipe Thread Connection
3/4 inch NPT

Discharge Coefficients
K = 11.2 GPM/psi^{1/2}
(161,3 LPM/bar^{1/2})

K = 14.0 GPM/psi^{1/2}
(201,6 LPM/bar^{1/2})

Temperature Ratings
135°F (57°C) to 286°F (141°C)

Finish
Sprinkler:
Refer to Table A

Recessed or Flush Escutcheon:
White-Coated, Chrome-Plated, and Brass-Plated

Physical Characteristics

Frame	Bronze
Button	Bronze
Sealing Assembly	Beryllium Nickel w/TEFLON
Bulb	Glass (3 mm dia.)
Compression Screw	Bronze
Deflector	Brass

Operation

The glass bulb contains a fluid that expands when exposed to heat. When the rated temperature is reached, the fluid expands sufficiently to shatter the glass bulb, which then allows the sprinkler to activate and flow water.

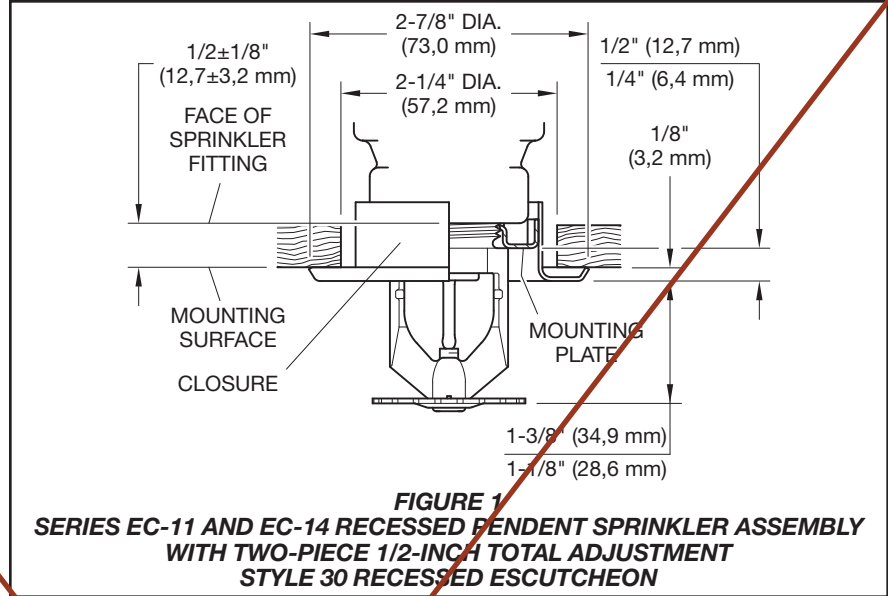

Design Criteria

TYCO Series EC-11 and EC-14 Extended Coverage Sprinklers must only be installed in accordance with the applicable UL and C-UL Listing or FM Approval requirements as indicated below. Only the Style 30 or 40 Recessed Escutcheon is to be used for recessed installation, as applicable.

Refer to Tables A, B, and C.

UL and C-UL Listing Requirements

- Series EC-11 and EC-14 Sprinklers may be used for the coverage areas shown in Table D, based on maintaining the minimum specified flow rate as a function of coverage area and hazard group for all sprinklers in the design area.
- Series EC-11 and EC-14 Sprinklers are permitted to be used with unobstructed or non-combustible obstructed ceiling construction as defined and permitted by NFPA 13; for example:
 - Unobstructed, combustible or noncombustible, ceiling construction with a deflector to ceiling/roof deck distance of 1 to 12 inches (25 to 300 mm).
 - Obstructed, non-combustible, ceiling construction with a deflector location below structural members of 1 to 6 inches (25 to 150 mm) and a maximum deflector to ceiling/roof deck distance of 22 inches (550 mm).

- Series EC-11 and EC-14 Sprinklers, specifically tested and listed for non-combustible obstructed construction, are permitted to be used within trusses or bar joists having non-combustible web members greater than 1 inch (25.4 mm) when applying the 4 times obstruction criteria rule defined under "Obstructions to Sprinkler Discharge Pattern Development".
- To prevent cold soldering, the minimum allowable spacing between Series EC-11 and EC-14 Sprinklers, is 8 feet (2,4 m) for upright sprinklers and 9 feet (2,7 m) for pendent sprinklers.
- Series EC-11 and EC-14 Sprinklers are to be installed in accordance with all other requirements of NFPA 13 for extended coverage upright and pendent sprinklers; For example, obstructions to sprinkler discharge, obstructions to sprinkler pattern development, obstructions to prevent sprinkler discharge from reaching hazard and clearance to storage.

SPRINKLERS SHALL BE WHITE CONCEALED IN FINISHED SPACES IN ACCORDANCE WITH CONTRACT DOCUMENT SPECIFICATIONS.

**UL and C-UL
Specific Application Listing
Requirements for Installation
under Concrete Tees**

Series EC-11 and EC-14 Extended Coverage Upright and Pendent Sprinklers (TY5137, TY5237, TY6137 and TY6237) have a UL and C-UL Specific Application Listing for use under concrete tees when installed as follows:

1. Stems of the concrete tee construction must spaced at less than 7.5 feet (2,3 m) on center but more than 3 feet (0,9 m) on center. The depth of the concrete tees must not exceed 30 inches (762 mm). The maximum permitted concrete tee length is 32 feet (9,8 m). However, where the concrete tee length exceeds 32 feet (9,8 m), non-combustible baffles, equal in height to the depth of the tees, can be installed so that the space between the tees does not exceed 32 feet (9,8 m) in length.
2. The sprinkler deflectors are to be located in a horizontal plane at or above 1 inch (25,4 mm) below the bottom of the concrete tee stems.
3. When the sprinkler deflectors are located higher than a horizontal plane 1 inch (25,4 mm) beneath the bottom of the concrete tee stems, the obstruction to sprinkler discharge criteria requirements of NFPA 13 for extended coverage upright sprinklers applies.

FM Approval Requirements

Series EC-11 and EC-14 Extended Coverage Sprinklers are to be installed in accordance with the applicable Factory Mutual Loss Prevention Data Sheet for limited use in buildings of specific roof construction and for the protection of certain specific ordinary hazard (non-storage and/or non-flammable or combustible liquid) occupancies. Information provided in the FM Loss Prevention Data Sheets relates to, but not limited to, hydraulic design, ceiling slope, and obstructions, minimum and maximum allowable spacing, and deflector-to-ceiling distance.

These criteria may differ from UL and/or NFPA criteria. Therefore, the designer should review and become familiar with Factory Mutual requirements before proceeding with design.

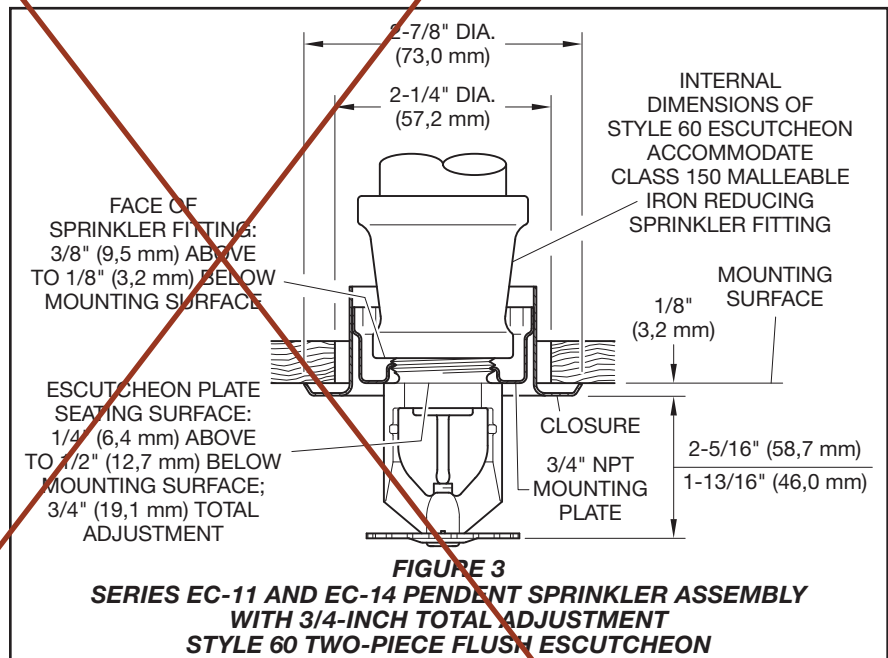
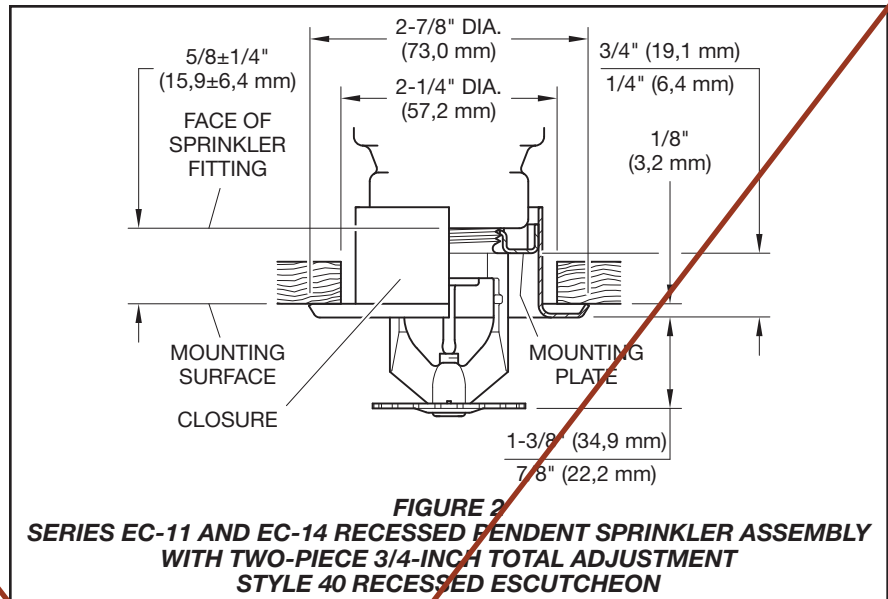

SPRINKLERS SHALL BE WHITE CONCEALED IN FINISHED SPACES IN ACCORDANCE WITH CONTRACT DOCUMENT SPECIFICATIONS.

Installation

Series EC-11 and EC-14 Sprinklers must be installed in accordance with this section.

General Instructions

Do not install any bulb-type sprinkler if the bulb is cracked or there is a loss of liquid from the bulb. With the sprinkler held horizontally, a small air bubble should be present. The diameter of the air bubble is approximately 1/16 inch (1,6 mm) for the 135°F (57°C) to 3/32 inch (2,4 mm) for the 286°F (141°C) temperature ratings.

A leak-tight 3/4 inch NPT sprinkler joint should be obtained by applying a minimum-to-maximum torque of 10 to 20 ft.-lbs. (13,4 to 26,8 Nm). Higher levels of torque may distort the sprinkler inlet with consequent leakage or impairment of the sprinkler.

Do not attempt to compensate for insufficient adjustment in an Escutcheon Plate by under or over-tightening the Sprinkler. Re-adjust the position of the sprinkler fitting to suit.

Step 1. Install the sprinkler with the deflector parallel to the mounting surface. Install pendent sprinklers in the pendent position; install upright sprinklers in the upright position.

Step 2. After installing the Style 30, 40, or 60 mounting plate (or other applicable escutcheon) over the sprinkler pipe threads and with pipe-thread sealant applied to the pipe threads, hand-tighten the sprinkler into the sprinkler fitting.

Step 3. For upright or pendent sprinklers wrench-tighten using only the W-Type 3 (End A) Sprinkler Wrench. For the pendent sprinkler installed with Style 30, 40, or 60 Escutcheon, wrench-tighten the sprinkler using only the W-Type 22 Sprinkler Wrench.

Apply the wrench recess of the applicable sprinkler wrench (Figure 5 and 6) to the sprinkler wrench flats (Figure 1).

Care and Maintenance

TYCO Series EC-11 and EC-14 Sprinklers must be maintained and serviced in accordance with this section.

Before closing a fire protection system main control valve for maintenance work on the fire protection system that it controls, obtain permission to shut down the affected fire protection systems from the proper authorities and notify all personnel who may be affected by this action.

Sprinklers which are found to be leaking or exhibiting visible signs of corrosion must be replaced.

Automatic sprinklers must never be painted, plated, coated, or otherwise altered after leaving the factory. Modified sprinklers must be replaced. Sprinklers that have been exposed to corrosive products of combustion, but have not operated, should be replaced if they cannot be completely cleaned by wiping the sprinkler with a cloth or by brushing it with a soft bristle brush.

Care must be exercised to avoid damage to the sprinklers before, during, and after installation. Sprinklers damaged by dropping, striking, wrench twist/slippage, or the like, must be replaced. Also, replace any sprinkler that has a cracked bulb or that has lost liquid from its bulb. (Ref. Installation Section.)

Frequent visual inspections are recommended to be initially performed for corrosion resistant coated sprinklers, after the installation has been completed, to verify the integrity of the corrosion resistant coating. Thereafter, annual inspections per NFPA 25 should suffice; however, instead of inspecting from the floor level, a random sampling of close-up visual inspections should be made, so as to better determine the exact sprinkler condition and the long term integrity of the corrosion resistant coating, as it may be affected by the corrosive conditions present.

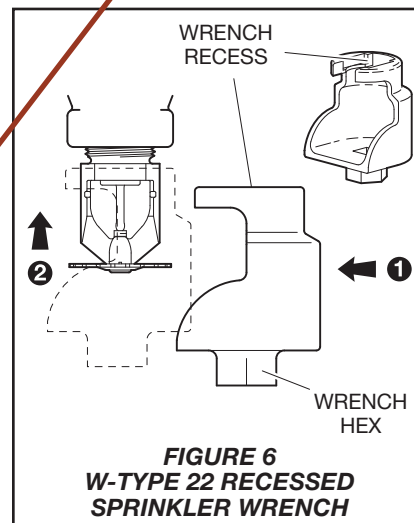
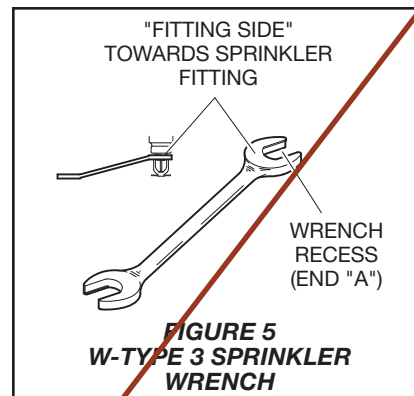

The owner is responsible for the inspection, testing, and maintenance of their fire protection system and devices in compliance with this document, as well as with the applicable standards recognized by the Approval agency (for example, NFPA 25), in addition to the standards of any authorities having jurisdiction. Contact the installing contractor or sprinkler manufacturer regarding any questions.

Automatic sprinkler systems are recommended to be inspected, tested, and maintained by a qualified Inspection Service in accordance with local requirements and/or national codes.

**SPRINKLERS SHALL BE WHITE CONCEALED
IN FINISHED SPACES IN ACCORDANCE WITH
CONTRACT DOCUMENT SPECIFICATIONS.**

Description	Area	Light Hazard 0.10 GPM/ft ²		Group I Ordinary Hazard 0.15 GPM/ft ²		Group II Ordinary Hazard 0.20 GPM/ft ²	
		GPM	PSI	GPM	PSI	GPM	PSI
TY5137 (K=11.2) Upright	14 x 14	30	7.2	30	7.2	39	12.1
	16 x 16	30	7.2	39	12.1	51	20.7
	18 x 18	33	8.7	49	19.1	65	33.7
	20 x 20	40	12.8	60	28.7	80	51.0
TY5237 (K=11.2) Pendent	14 x 14	30	7.2	30	7.2	39	12.1
	16 x 16	30	7.2	39	12.1	51	20.7
	18 x 18	33	8.7	49	19.1	65	33.7
	20 x 20	40	12.8	60	28.7	80	51.0
TY6137 (K=14.0) Upright	14 x 14	N/A	N/A	39	7.8	51	13.3
	16 x 16	N/A	N/A	39	7.8	51	13.3
	18 x 18	N/A	N/A	49	12.3	65	21.6
	20 x 20	N/A	N/A	60	18.4	80	32.7
TY6237 (K=14.0) Pendent	14 x 14	37	7.0	39	7.8	51	13.3
	16 x 16	37	7.0	39	7.8	51	13.3
	18 x 18	37	7.0	49	12.3	65	21.6
	20 x 20	40	8.2	60	18.4	80	32.7

1 ft. = 0.3048 m
1 ft.² = 0.093 m²
1 GPM = 3.785 LPM

1 psi = 0.06895 bar
1 GPM/ft² = 40.74 mm/min

TABLE D
FLOW CRITERIA FOR UL AND C-UL LISTING OF SERIES EC-11 AND EC-14 SPRINKLERS

SPRINKLERS SHALL BE WHITE CONCEALED
IN FINISHED SPACES IN ACCORDANCE WITH
CONTRACT DOCUMENT SPECIFICATIONS.

Series DS-3 Dry-Type Sprinklers 11.2 K-factor Horizontal Sidewall, Extended Coverage, Standard Response

General Description

TYCO Series DS-3 Dry-Type Sprinklers, 11.2 K-factor Horizontal Sidewall, Standard Response, Extended Coverage, Ordinary Hazard, are decorative glass bulb automatic sprinklers. They are intended for use in applications where the sprinklers and/or a portion of the connecting piping may be exposed to freezing temperatures; for example, horizontal piping extensions through a wall to protect an unheated area of a building.

Series DS-3 Extended Coverage Ordinary Hazard Horizontal Sidewall, Dry-Type Sprinklers are designed for extended coverage use in ordinary hazard occupancies (ECOH) per NFPA 13.

Series DS-3 Dry-Type Sprinklers provide protection of coverage areas up to 16 ft. x 20 ft. (320 ft²) as compared to standard coverage horizontal sidewall sprinklers having a maximum coverage area of 10 ft. x 10 ft. (100 ft²) for ordinary hazard occupancies.

NOTICE

Series DS-3 Dry-Type Sprinklers described herein must be installed and maintained in compliance with this document, as well as with the applicable standards of the National Fire Protection Association, in addition to the standards of any other authorities having jurisdiction. Failure to do so may impair the performance of these devices.

IMPORTANT

Always refer to Technical Data Sheet TFP700 for the "INSTALLER WARNING" that provides cautions with respect to handling and installation of sprinkler systems and components. Improper handling and installation can permanently damage a sprinkler system or its components and cause the sprinkler to fail to operate in a fire situation or cause it to operate prematurely.

The owner is responsible for maintaining their fire protection system and devices in proper operating condition. The installing contractor or sprinkler manufacturer should be contacted with any questions.

Series DS-3 Dry-Type Sprinklers must only be installed in fittings that meet the requirements of the Design Criteria section. Installation of Series DS-3 Dry-Type Sprinklers in a recessed installation will void all sprinkler warranties, as well as void the sprinkler's laboratory approvals.

Sprinkler Identification Number (SIN)

TY5339

Technical Data

Approvals

UL and C-UL Listed

Refer to Table A and the Design Criteria Section.

Maximum Working Pressure

175 psi (12,1 bar)

Inlet Thread Connections

- 1 Inch NPT (Standard)
- ISO 7-R1 (For information on ISO Inlet Thread Connections, contact your Tyco Sales Representative.)

Discharge Coefficient

Refer to Table B.

Temperature Ratings

155°F (68°C) and 200°F (93°C)

Finishes

Sprinkler: Natural Brass, Chrome Plated, Signal White

Escutcheon: Signal White or Chrome Plated, Brass Plated



Physical Characteristics

Inlet	Copper
Plug	Copper
Yoke	Stainless Steel
Casing	Galvanized Carbon Steel
Insert	Bronze
Bulb Seat	Bronze
Bulb	Glass (3 mm)
Compression Screw	Bronze
Deflector	Bronze
Frame	Bronze
Guide Tube	Stainless Steel
Water Tube	Stainless Steel
Spring	Stainless Steel
Gasketed Spring Plate Seal	Beryllium Nickel w/TEFLON
Pin	Stainless Steel
Button Spring	Stainless Steel
Helper Spring	Stainless Steel
Escutcheon	Carbon Steel

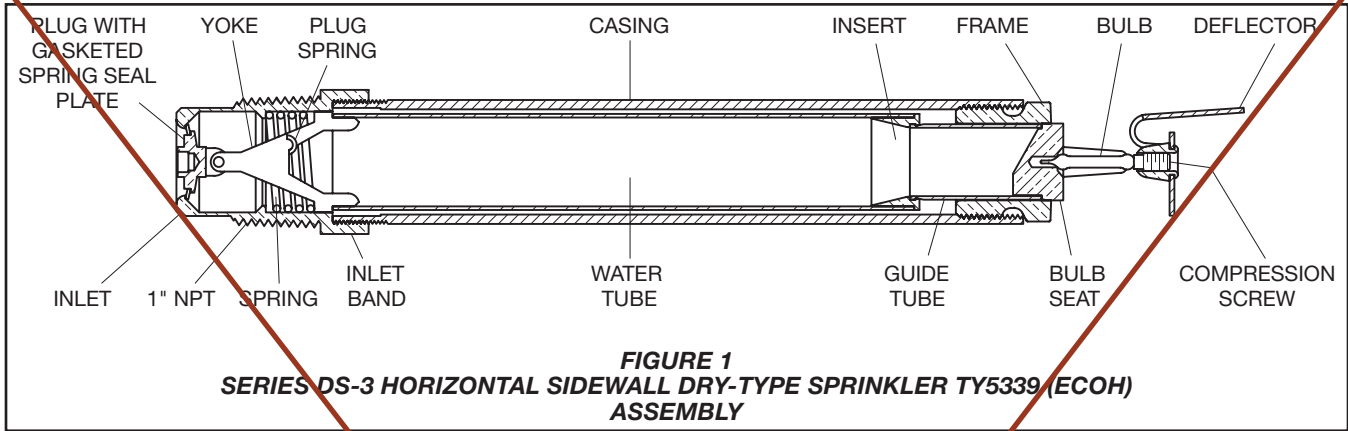

Temperature Rating	Bulb Color Code	SPRINKLER FINISH		
		Natural Brass	Chrome Plated	Signal White
155°F (68°C)	Red	Listed by Underwriters Laboratories, Inc. (maximum order length of 48 inches)		
200°F (93°C)	Green	Listed by Underwriters Laboratories for use in Canada (maximum order length of 48 inches)		

TABLE A
SERIES DS-3 HORIZONTAL SIDEWALL DRY-TYPE SPRINKLERS
EXTENDED COVERAGE, ORDINARY HAZARD (TY5339)
LABORATORY LISTINGS AND APPROVALS

K-factor LENGTH Inches (mm)	K-factor GPM/psi ^{1/2} (LPM/bar ^{1/2})
2-1/2 to 14-3/4 (63 mm to 375 mm)	11.2 (161,3)
15 to 18-3/4 (381 mm to 476 mm)	10.9 (157,0)
19 to 23 (483 mm to 584 mm)	10.8 (155,5)
23-1/4 to 26-3/4 (591 mm to 679 mm)	10.7 (154,1)
27-1/4 to 31-1/4 (692 mm to 794 mm)	10.6 (152,6)
31-1/2 to 35-1/4 (800 mm to 895 mm)	10.5 (151,2)
35-1/2 to 39-1/2 (902 mm to 1003 mm)	10.4 (149,8)
39-3/4 to 43-1/2 (1010 mm to 1105 mm)	10.3 (148,3)
43-3/4 to 48 (111 mm to 1219 mm)	10.2 (146,9)

Notes
K-factor Length is determined as follows:
 • Flush: Order Length from Figure 2 plus 1/2 inch (12,7 mm)
 • Deep: Order Length from Figure 4 plus 3-1/4 inch (82,6 mm)
 • Without Escutcheon: Order Length from Figure 5 minus 2-1/4 inches (57,2 mm)

TABLE B
DISCHARGE COEFFICIENTS

Operation

When TYCO Series DS-3 Dry-Type Sprinklers are in service, water is prevented from entering the assembly by the Plug with Gasketed Spring Seal Plate (Figure 1) in the Inlet of the Sprinkler.

The glass bulb contains a fluid that expands when exposed to heat. When the rated temperature is reached, the fluid expands sufficiently to shatter the glass bulb, and the Bulb Seat is released.

The compressed Spring is then able to expand and push the Water Tube as well as the Guide Tube outward. This action simultaneously pulls inward on the Yoke, withdrawing the Plug with Gasketed Spring Seal Plate from the Inlet allowing the sprinkler to activate and flow water.

Design Criteria

TYCO Series DS-3, Standard Response, Extended Coverage Ordinary Hazard, Horizontal Sidewall, Dry-Type Sprinklers (ECOH) are for use in ordinary hazard occupancies with non-combustible unobstructed construction and with a ceiling slope

not exceeding 2 inches per foot (9.2°), using the design criteria provided in Table C, as well as any additional requirements specified in NFPA 13 for Extended Coverage Sidewall Spray Sprinklers.

A 36 inch (914 mm) clearance must be maintained between the top of the sprinkler deflector and any miscellaneous storage.

Series DS-3 Dry-Type Sprinklers may be installed on sloped ceilings in loading docks with a maximum roof slope of 4 inches per foot (18.4°) as shown in Figure 8 and using the design criteria provided in Table C.

Sprinkler Fittings

Install 1 Inch NPT Series DS-3 Dry-Type Sprinklers in the 1 Inch NPT outlet or run of the following fittings:

- malleable or ductile iron threaded tee fittings that meet the dimensional requirements of ANSI B16.3 (Class 150)
- cast iron threaded tee fittings that meet the dimensional requirements of ANSI B16.4 (Class 125).

Do not install Series DS-3 Dry-Type Sprinklers into elbow fittings. The Inlet of the sprinkler can contact the interior of the elbow.

Application	Coverage Area ¹ W x L Ft. x Ft. (m x m)	Minimum Flow ² GPM (LPM)	Min Pressure ² PSI (bar)	Top Of Deflector-to-Ceiling Distance ³ , Inches (mm)	Temperature Rating °F (°C)	Minimum Spacing ⁴ Ft. (m)
Series DS-3 (TY5339) Horizontal Sidewall Dry-Type Sprinkler (ECO) OH Group 1 (0.15 gpm/sq.ft) Standard Response	16 x 16 (4,9 x 4,4)	38 (144)	11.5 (0,79)	6 to 12 (150 to 300)	155, 200 (68, 93)	8 (2,4)
	16 x 18 (4,9 x 5,5)	43 (163)	14.7 (1,01)			
	16 x 20 (4,9 x 6,1)	48 (182)	18.4 (1,27)			
Series DS-3 (TY5339) Horizontal Sidewall Dry-Type Sprinkler (ECO) OH Group 2 (0.20 gpm/sq.ft) Standard Response	16 x 16 (4,9 x 4,4)	51 (193)	20.7 (1,43)			
	16 x 18 (4,9 x 5,5)	58 (220)	26.8 (1,85)			
	16 x 20 (4,9 x 6,1)	64 (242)	32.7 (2,25)			

Notes

1. Backwall (where sprinkler is located) by sidewall (length of throw).
2. Requirement is based on minimum flow in GPM from each sprinkler. The indicated residual pressures are based on the nominal K-factor of 11.2.
3. The centerline of the sprinkler waterway is located below the deflector as shown in Figures 2, 3, and 4.
4. Minimum spacing is for lateral distance between sprinklers located along a single wall. Otherwise adjacent sprinklers (that is, sidewall sprinklers on an adjacent wall, on an opposite wall, or pendent sprinklers) must be located outside of the maximum listed protection area of the extended coverage sidewall sprinkler being utilized.

TABLE C
SERIES DS-3 EXTENDED COVERAGE HORIZONTAL SIDEWALL DRY-TYPE SPRINKLERS
UL AND C-UL LISTING COVERAGE AND FLOW RATE CRITERIA

Ambient Temperature Exposed to Discharge End of Sprinkler	Temperatures for Heated Area ¹		
	40°F (4°C)	50°F (10°C)	60°F (16°C)
	Minimum Exposed Barrel Length, Inches (mm) ²		
40°F (4°C)	0	0	0
30°F (-1°C)	0	0	0
20°F (-7°C)	4 (100)	0	0
10°F (-12°C)	8 (200)	1 (25)	0
0°F (-18°C)	12 (305)	3 (75)	0
-10°F (-23°C)	14 (355)	4 (100)	1 (25)
-20°F (-29°C)	14 (355)	6 (150)	3 (75)
-30°F (-34°C)	16 (405)	8 (200)	4 (100)
-40°F (-40°C)	18 (455)	8 (200)	4 (100)
-50°F (-46°C)	20 (510)	10 (255)	6 (150)
-60°F (-51°C)	20 (510)	10 (255)	6 (150)

Notes

1. For protected area temperatures that occur between values listed above, use the next cooler temperature.
2. These lengths are inclusive of wind velocities up to 30 mph (18,6 kph).

TABLE D
EXPOSED SPRINKLER BARRELS IN WET PIPE SYSTEMS
MINIMUM RECOMMENDED LENGTHS

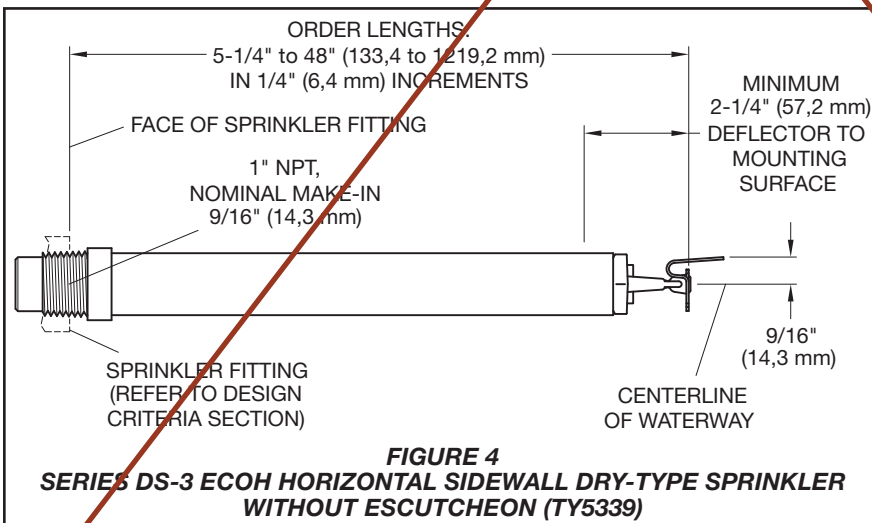
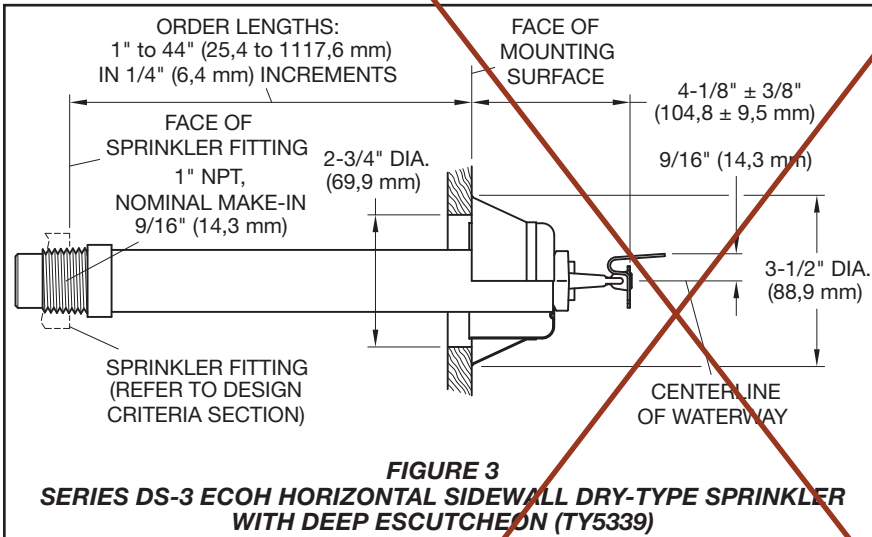
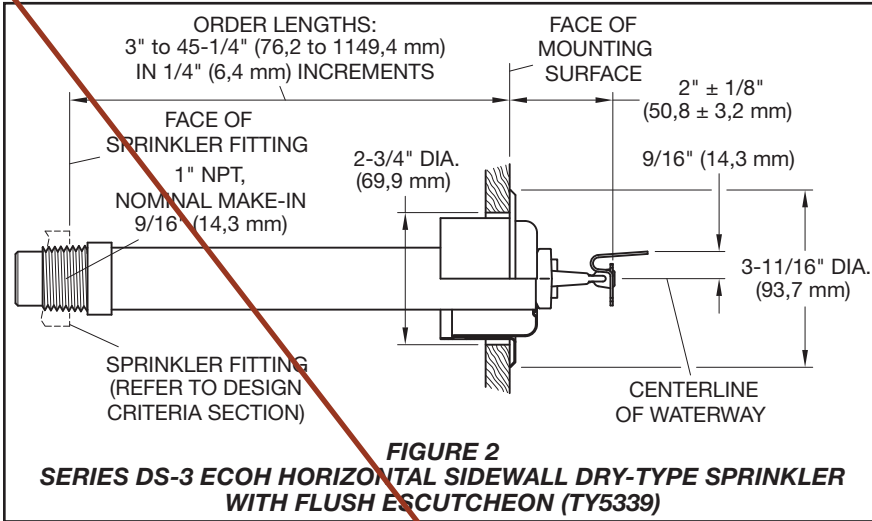

The unused outlet of the threaded tee is plugged as shown in Figure 6.

Series DS-3 Dry-Type Sprinklers can also be installed in the 1 Inch NPT outlet of a GRINNELL Figure 730 Mechanical Tee. However, the use of the Figure 730 Tee for this arrangement is limited to wet pipe systems.

The configuration shown in Figure 7 is only applicable for wet pipe systems where the sprinkler fitting and water-filled pipe above the sprinkler fitting are not subject to freezing and where the length of the Dry-Type Sprinkler has the minimum exposure length depicted in Figure 10. Refer to the Exposure Length section.

For wet pipe system installations of 1 Inch NPT Series DS-3 Dry-Type Sprinklers connected to CPVC piping, use only the following TYCO CPVC fittings:

- 1" x 1" NPT Female Adapter (P/N 80145)
- 1" x 1" x 1" NPT Sprinkler Head Adapter Tee (P/N 80249).

For dry pipe system installations, use only the side outlet of maximum 2-1/2 inch reducing tee when locating Series DS-3 Dry-Type Sprinklers directly below the branch line. Otherwise, use the configuration shown in Figure 6 to assure complete water drainage from above Series DS-3 Dry-Type Sprinklers and the branch line. Failure to do so may result in pipe freezing and water damage.

NOTICE

Do not install Series DS-3 Dry-Type Sprinkler into any other type fitting without first consulting the Technical Services Department. Failure to use the appropriate fitting may result in one of the following:

- Failure of the sprinkler to operate properly due to formation of ice over the Inlet Plug or binding of the Inlet Plug.
- Insufficient engagement of the Inlet pipe-threads with consequent leakage.

Drainage

In accordance with the minimum requirements of the National Fire Protection Association for dry pipe sprinkler systems, branch, cross, and feed-main piping connected to Dry Sprinklers and subject to freezing temperatures must be pitched for proper drainage.

Exposure Length

When using Dry Sprinklers in wet pipe sprinkler systems to protect areas subject to freezing temperatures, use Table D to determine a sprinkler's

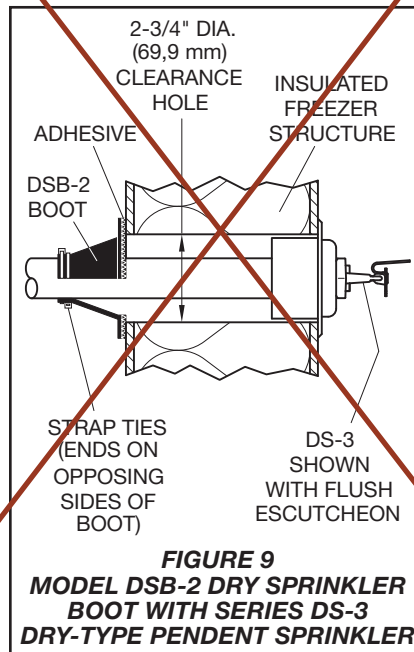
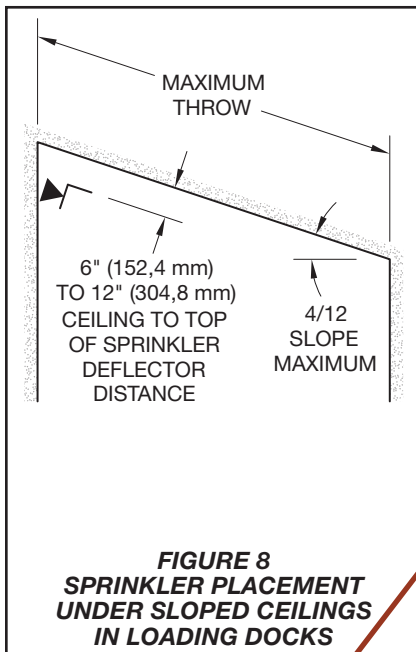
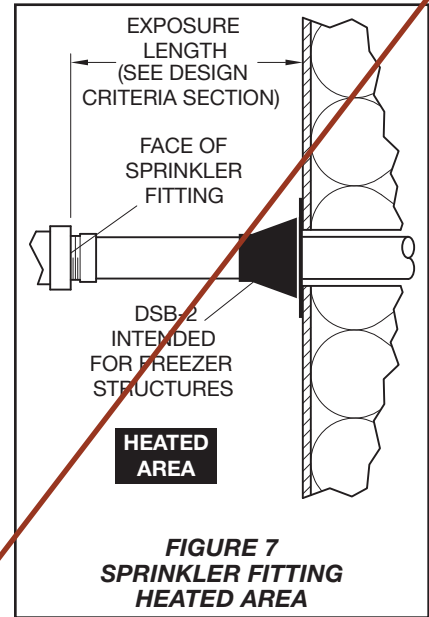
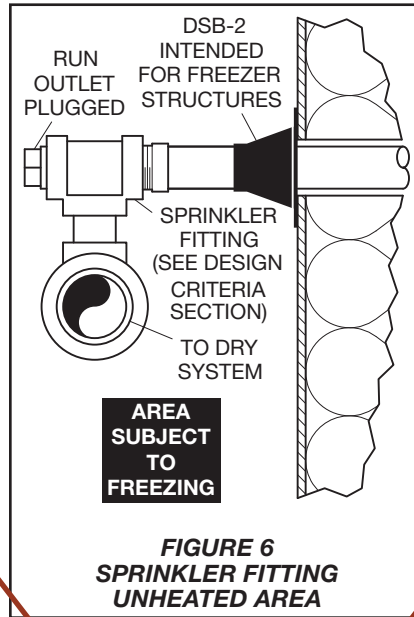
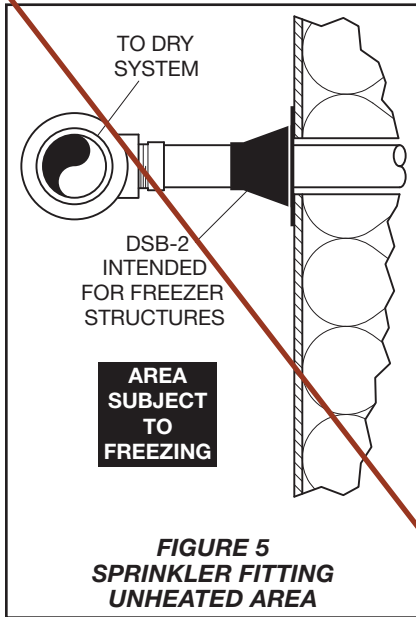

appropriate exposed barrel length to prevent water from freezing in the connecting pipes due to conduction. The exposed barrel length measurement must be taken from the face of the sprinkler fitting to the surface of the structure or insulation that is exposed to the heated area. Refer to Figure 7 for an example.

For protected area temperatures between those given above, the minimum recommended length from the face of the fitting to the outside of the protected area may be determined by interpolating between the indicated values.

Clearance Space

In accordance with Section 8.4.9.2 of the 2010 edition of NFPA 13, when connecting an area subject to freezing and an area containing a wet pipe sprinkler system, the clearance space around the sprinkler barrel of Dry-Type Sprinklers must be sealed. Due to temperature differences between two areas, the potential for the formation of condensation in the sprinkler and subsequent ice build-up is increased. If this condensation is not controlled, ice build-up can occur that might damage the dry-type sprinkler and/or prevent proper operation in a fire situation.

Use of the Model DSB-2 Dry Sprinkler Boot, described in technical data sheet TFP591 and shown in Figure 9, can provide the recommended seal.

HYDRAULIC CALCULATIONS

ACCURATE FIRE PROTECTION
1428 Gravois Road
High Ridge, Mo. 63049
636-677-9190

Job Name : ORCHARD FARMS EARLY CHILDHOOD- CALC AREA A
Building :
Location :
System :
Contract :
Data File : ORCHARD FARMS EARLY CHILDHOOD- CALC 2 DRAWING Area 2.WXF

Water Supply Curve C

ACCURATE FIRE PROTECTION
 ORCHARD FARMS EARLY CHILDHOOD- CALC AREA A

City Water Supply:
 C1 - Static Pressure : 121
 C2 - Residual Pressure: 110
 C2 - Residual Flow : 1694

Demand:
 D1 - Elevation : 4.257
 D2 - System Flow : 214.89
 D2 - System Pressure : 87.756
 Hose (Demand) : 100
 D3 - System Demand : 314.89
 Safety Margin : 32.754

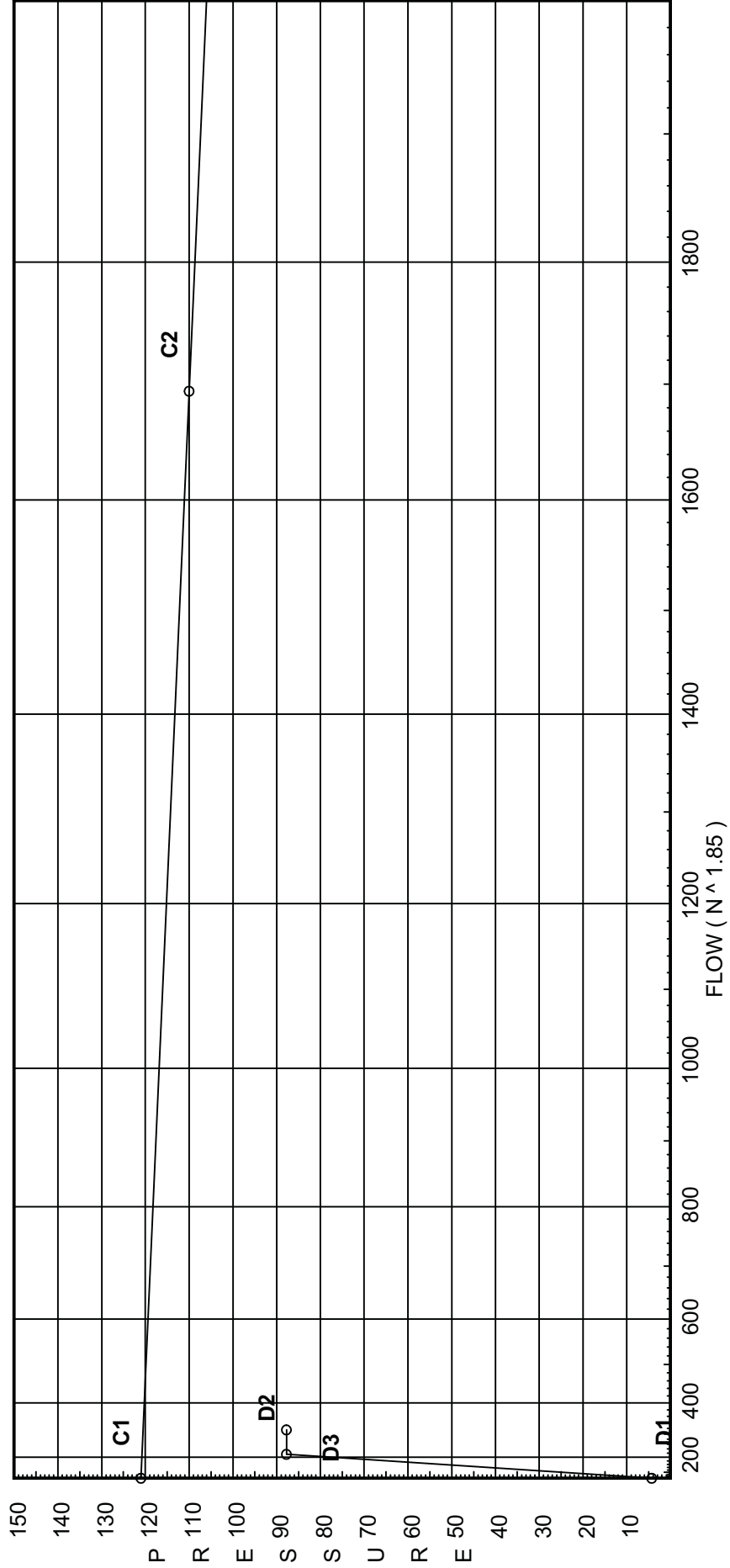

Pressure / Flow Summary - STANDARD

ACCURATE FIRE PROTECTION
 ORCHARD FARMS EARLY CHILDHOOD- CALC AREA A

Page 2
 Date

Node No.	Elevation	K-Fact	Pt Actual	Pn	Flow Actual	Density	Area	Press Req.
DP02	8.83	11.2	8.7	na	33.04	0.1	330	8.7
EQ02	9.83		10.24	na				
DP01	8.83	11.2	8.7	na	33.04	0.1	330	8.7
EQ01	9.83		9.25	na				
50	9.83	K = K @ EQ01	9.25	na	33.04			
51	9.83	K = K @ EQ02	10.47	na	33.4			
52	9.83		12.97	na				
53	9.83		52.77	na				
15	11.46		74.19	na				
55	11.46		74.6	na				
56	3.0		79.41	na				
BFD	3.0		80.73	na				
BFS	0.0		86.16	na				
TEST	0.0		87.76	na	100.0			
59	9.83	K = K @ EQ01	10.68	na	35.49			
60	9.83	K = K @ EQ01	10.43	na	35.08			
61	9.83		12.23	na				
62	9.83		19.69	na				
63	9.83		51.67	na				
64	9.83	K = K @ EQ01	9.93	na	34.22			
65	9.83	K = K @ EQ01	16.17	na	43.67			

The maximum velocity is 24.23 and it occurs in the pipe between nodes 62 and 63

Final Calculations - Hazen-Williams

ACCURATE FIRE PROTECTION
 ORCHARD FARMS EARLY CHILDHOOD- CALC AREA A

Page 3
 Date

Hyd. Ref. Point	Qa Qt	Dia. "C" Pf/Ft	Fitting or Eqv.	Ln.	Pipe Ftg's Total	Pt Pe Pf	Pt Pv Pn	*****	Notes	*****
DP02 to EQ02	33.04	1.049 120.0 0.3293	T	5.0 0.0 0.0	1.000 5.000 6.000	8.700 -0.433 1.976			K Factor = 11.20 Vel = 12.27	
	0.0 33.04						10.243		K Factor = 10.32	
DP01 to EQ01	33.04	1.049 120.0 0.3293	E	2.0 0.0 0.0	1.000 2.000 3.000	8.700 -0.433 0.988			K Factor = 11.20 Vel = 12.27	
	0.0 33.04						9.255		K Factor = 10.86	
50 to 51	33.04	1.38 120.0 0.0866		0.0 0.0 0.0	14.000 0.0 14.000	9.255 0.0 1.212			K Factor @ node EQ01 Vel = 7.09	
51 to 52	33.39	1.38 120.0 0.3154		0.0 0.0 0.0	7.940 0.0 7.940	10.467 0.0 2.504			K Factor @ node EQ02 Vel = 14.25	
52 to 53	35.49	1.38 120.0 0.6962	2E T	6.0 6.0 0.0	45.160 12.000 57.160	12.971 0.0 39.795			Vel = 21.86	
53 to 15	112.97	2.157 120.0 0.3143	5E	30.767 0.0 0.0	39.650 30.767 70.417	52.766 -0.706 22.135			Vel = 18.87	
15 to 55	0.0	3.26 120.0 0.0421		0.0 0.0 0.0	9.630 0.0 9.630	74.195 0.0 0.405			Vel = 8.26	
55 to 56	0.0	3.26 120.0 0.0421	2E	18.815 0.0 0.0	8.460 18.815 27.275	74.600 3.664 1.147			Vel = 8.26	
56 to BFD	0.0	4.1 140.0 0.0104	5E	72.668 0.0 0.0	54.830 72.668 127.498	79.411 0.0 1.321			Vel = 5.22	
BFD to BFS	0.0	4.26 120.0 0.0115	Zcb	0.0 0.0 0.0	1.910 0.0 1.910	80.732 5.404 0.022			** Fixed Loss = 4.105 Vel = 4.84	
BFS to TEST	0.0	4.1 140.0 0.0103	E T 2G	14.534 29.067 5.813	105.000 49.414 154.414	86.158 0.0 1.598			Vel = 5.22	
	100.00 314.89						87.756		Qa = 100.00 K Factor = 33.61	
59 to 52	35.49	1.049 120.0 0.3759	T	5.0 0.0 0.0	1.090 5.000 6.090	10.682 0.0 2.289			K Factor @ node EQ01 Vel = 13.17	
	0.0 35.49						12.971		K Factor = 9.85	
60 to 61	35.08	1.38 120.0 0.0968	E	3.0 0.0 0.0	15.530 3.000 18.530	10.435 0.0 1.793			K Factor @ node EQ01 Vel = 7.52	
61 to 62	34.22	1.38 120.0 0.3410	2E	6.0 0.0 0.0	15.870 6.000 21.870	12.228 0.0 7.458			Vel = 14.86	

Final Calculations - Hazen-Williams

ACCURATE FIRE PROTECTION
 ORCHARD FARMS EARLY CHILDHOOD- CALC AREA A

Page 4
 Date

Hyd. Ref. Point	Qa Qt	Dia. "C" Pf/Ft	Fitting or Eqv. Ln.	Pipe Ftng's Total	Pt Pe Pf	Pt Pv Pn	*****	Notes	*****
62	43.67	1.38	T 6.0	31.980	19.686				
to		120.0	0.0	6.000	0.0				
63	112.97	0.8422	0.0	37.980	31.987		Vel = 24.23		
63	0.0	2.157	0.0	11.420	51.673				
to		120.0	0.0	0.0	0.0				
53	112.97	0.0957	0.0	11.420	1.093		Vel = 9.92		
	0.0								
	112.97				52.766		K Factor = 15.55		
64	34.22	1.049	T 5.0	1.530	9.932		K Factor @ node EQ01		
to		120.0	0.0	5.000	0.0				
61	34.22	0.3516	0.0	6.530	2.296		Vel = 12.70		
	0.0								
	34.22				12.228		K Factor = 9.79		
65	43.67	1.049	T 5.0	1.370	16.171		K Factor @ node EQ01		
to		120.0	0.0	5.000	0.0				
62	43.67	0.5518	0.0	6.370	3.515		Vel = 16.21		
	0.0								
	43.67				19.686		K Factor = 9.84		

HYDRAULIC CALCULATIONS

ACCURATE FIRE PROTECTION
1428 Gravois Road
High Ridge, Mo. 63049
636-677-9190

Job Name : ORCHARD FARMS EARLY CHILDHOOD- AREA B CALC
Building :
Location :
System :
Contract :
Data File : ORCHARD FARMS EARLY CHILDHOOD- CALC AREA B 1.WXF

Water Supply Curve C

ACCURATE FIRE PROTECTION
 ORCHARD FARMS EARLY CHILDHOOD- AREA B CALC

City Water Supply:
 C1 - Static Pressure : 121
 C2 - Residual Pressure: 110
 C2 - Residual Flow : 1694

Demand:
 D1 - Elevation : 10.646
 D2 - System Flow : 349.038
 D2 - System Pressure : 96.760
 Hose (Demand) : 100
 D3 - System Demand : 449.038
 Safety Margin : 23.297

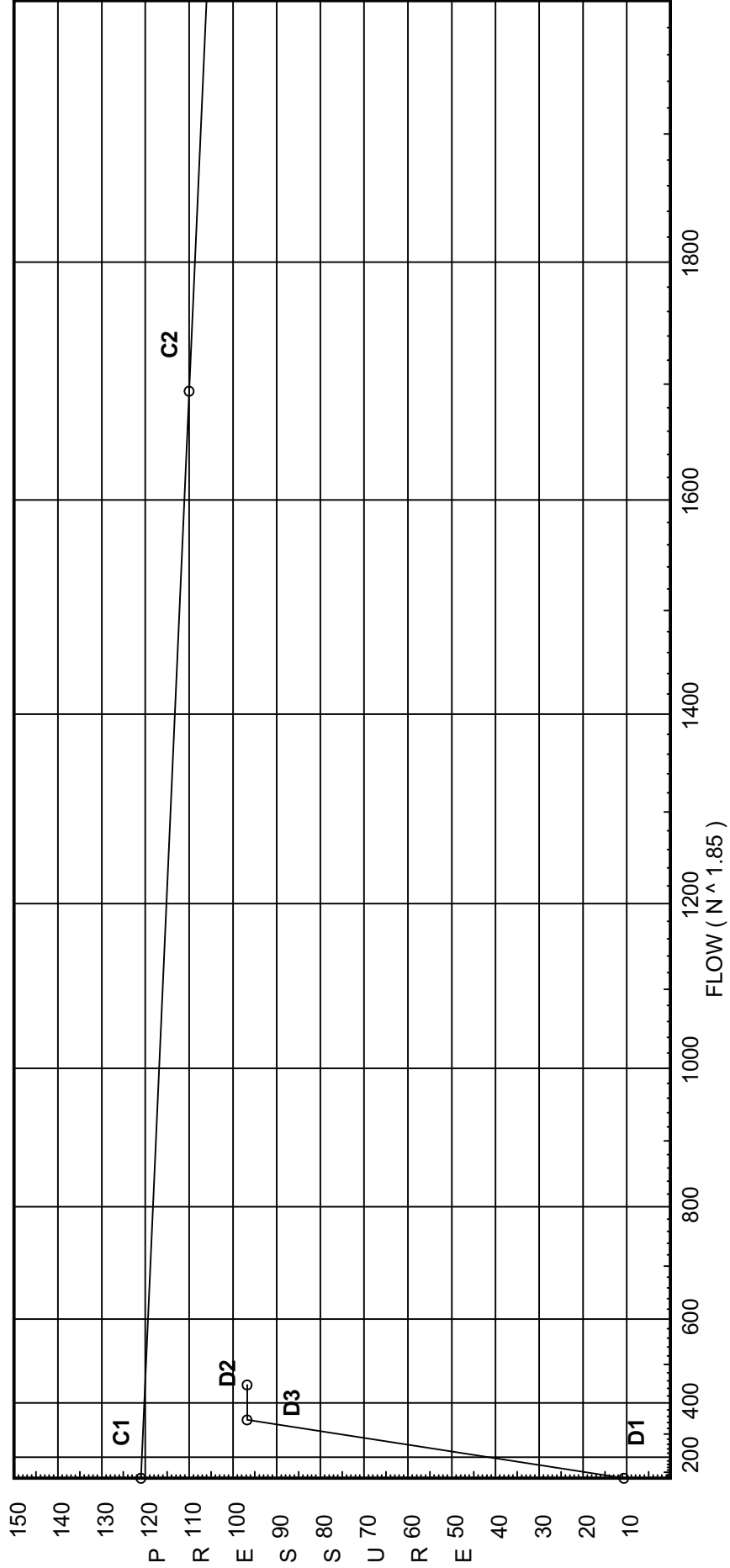

Pressure / Flow Summary - STANDARD

ACCURATE FIRE PROTECTION
 ORCHARD FARMS EARLY CHILDHOOD- AREA B CALC

Page 2
 Date

Node No.	Elevation	K-Fact	Pt Actual	Pn	Flow Actual	Density	Area	Press Req.
DP01	8.83	11.2	8.7	na	33.04	0.1	330	8.7
EQ01	9.83		10.24	na				
DP02	8.83	5.6	7.17	na	15.0	0.1	150	7.0
EQ02	9.83		6.82	na				
DP03	23.58	11.2	8.7	na	33.04	0.1	330	8.7
EQ03	24.58		9.25	na				
DP04	23.58	11.2	8.7	na	33.04	0.1	330	8.7
EQ04	24.58		10.24	na				
1	9.83	K = K @ EQ02	12.62	na	20.4			
2	9.83		14.31	na				
3	9.83	K = K @ EQ01	14.65	na	39.51			
4	9.83		14.84	na				
5	9.83	K = K @ EQ01	19.85	na	45.99			
6	9.83		30.87	na				
7	10.46		38.2	na				
8	10.46		38.45	na				
9	9.83		39.31	na				
10	9.83		51.19	na				
11	11.46		51.41	na				
12	11.46		51.51	na				
13	11.46		52.15	na				
14	11.46		57.42	na				
15	11.46		74.23	na				
16	3.0		82.07	na				
BFD	3.0		84.94	na				
BFS	3.0		91.37	na				
TEST	0.0		96.76	na	100.0			
19	24.58	K = K @ EQ03	10.07	na	34.46			
20	24.58	K = K @ EQ04	10.24	na	33.04			
21	24.58	K = K @ EQ04	10.83	na	33.97			
22	9.83		23.81	na				
23	9.83		48.3	na				
24	9.83	K = K @ EQ02	12.9	na	20.63			
25	9.83		14.32	na				
26	9.83		14.75	na				
27	9.83	K = K @ EQ01	15.09	na	40.09			
28	9.83		23.81	na				
29	9.83		47.77	na				
30	9.83	K = K @ EQ02	13.37	na	21.0			
31	9.83	K = K @ EQ02	13.29	na	20.94			
32	9.83	K = K @ EQ01	14.27	na	38.99			
33	10.46		40.45	na				
34	10.46		40.75	na				
35	9.83		41.77	na				
36	9.83		55.96	na				
37	11.46		56.8	na				
38	11.46		56.92	na				
39	9.83		41.42	na				
40	9.83		56.54	na				

The maximum velocity is 20.54 and it occurs in the pipe between nodes 14 and 15

Final Calculations - Hazen-Williams

ACCURATE FIRE PROTECTION
 ORCHARD FARMS EARLY CHILDHOOD- AREA B CALC

Page 3
 Date

Hyd. Ref. Point	Qa Qt	Dia. "C" Pf/Ft	Fitting or Eqv.	Ln.	Pipe Ftng's Total	Pt Pe Pf	Pt Pv Pn	*****	Notes	*****
DP01 to EQ01	33.04 33.04	1.049 120.0 0.3293	T	5.0 0.0 0.0	1.000 5.000 6.000	8.700 -0.433 1.976			K Factor = 11.20 Vel = 12.27	
	0.0 33.04						10.243		K Factor = 10.32	
DP02 to EQ02	15.00 15.0	1.049 120.0 0.0760		0.0 0.0 0.0	1.000 0.0 1.000	7.175 -0.433 0.076			K Factor = 5.60 Vel = 5.57	
	0.0 15.00						6.818		K Factor = 5.74	
DP03 to EQ03	33.04 33.04	1.049 120.0 0.3293	E	2.0 0.0 0.0	1.000 2.000 3.000	8.700 -0.433 0.988			K Factor = 11.20 Vel = 12.27	
	0.0 33.04						9.255		K Factor = 10.86	
DP04 to EQ04	33.04 33.04	1.049 120.0 0.3293	T	5.0 0.0 0.0	1.000 5.000 6.000	8.700 -0.433 1.976			K Factor = 11.20 Vel = 12.27	
	0.0 33.04						10.243		K Factor = 10.32	
1 to 2	20.40 20.4	1.049 120.0 0.1350	E T	2.0 5.0 0.0	5.560 7.000 12.560	12.616 0.0 1.696			K Factor @ node EQ02 Vel = 7.57	
2 to 3	15.31 35.71	1.682 120.0 0.0382		0.0 0.0 0.0	8.850 0.0 8.850	14.312 0.0 0.338			Vel = 5.16	
3 to 4	39.51 75.22	1.682 120.0 0.1512		0.0 0.0 0.0	1.230 0.0 1.230	14.650 0.0 0.186			K Factor @ node EQ01 Vel = 10.86	
4 to 5	21.00 96.22	1.682 120.0 0.2388	2E	9.9 0.0 0.0	11.090 9.900 20.990	14.836 0.0 5.012			Vel = 13.89	
5 to 6	45.99 142.21	1.682 120.0 0.4918		0.0 0.0 0.0	22.410 0.0 22.410	19.848 0.0 11.021			K Factor @ node EQ01 Vel = 20.53	
6 to 7	0.0 142.21	1.682 120.0 0.4918	E T	4.95 9.9 0.0	0.620 14.850 15.470	30.869 -0.273 7.608			Vel = 20.53	
7 to 8	-98.11 44.1	2.157 120.0 0.0168		0.0 0.0 0.0	14.440 0.0 14.440	38.204 0.0 0.242			Vel = 3.87	
8 to 9	0.0 44.1	1.682 120.0 0.0564	T	9.9 0.0 0.0	0.620 9.900 10.520	38.446 0.273 0.593			Vel = 6.37	
9 to 10	0.0 44.1	1.682 120.0 0.0564	T 6E	9.9 29.699 0.0	171.040 39.599 210.639	39.312 0.0 11.876			Vel = 6.37	
10 to 11	0.0 44.1	1.682 120.0 0.0564	T E	9.9 4.95 0.0	1.630 14.850 16.480	51.188 -0.706 0.929			Vel = 6.37	

Final Calculations - Hazen-Williams

ACCURATE FIRE PROTECTION
 ORCHARD FARMS EARLY CHILDHOOD- AREA B CALC

Page 4
 Date

Hyd. Ref. Point	Qa Qt	Dia. "C" Pf/Ft	Fitting or Eqv.	Ln.	Pipe Ftg's Total	Pt Pe Pf	Pt Pv Pn	*****	Notes	*****
11	0.0	2.635		0.0	15.730	51.411				
to		120.0		0.0	0.0	0.0				
12	44.1	0.0063		0.0	15.730	0.099		Vel =	2.59	
12	102.74	2.635		0.0	10.830	51.510				
to		120.0		0.0	0.0	0.0				
13	146.84	0.0586		0.0	10.830	0.635		Vel =	8.64	
13	104.09	2.635	T	16.474	16.910	52.145				
to		120.0		0.0	16.474	0.0				
14	250.93	0.1580		0.0	33.384	5.275		Vel =	14.76	
14	98.11	2.635		0.0	57.790	57.420				
to		120.0		0.0	0.0	0.0				
15	349.04	0.2909		0.0	57.790	16.812		Vel =	20.54	
15	0.0	3.26	T	20.159	10.850	74.232				
to		120.0	E	9.408	29.567	3.664				
16	349.04	0.1032		0.0	40.417	4.170		Vel =	13.42	
16	0.0	4.1	4E	58.134	54.930	82.066				
to		140.0		0.0	58.134	0.0				
BFD	349.04	0.0254		0.0	113.064	2.872		Vel =	8.48	
BFD	0.0	4.26	Zcb	0.0	2.220	84.938				
to		120.0		0.0	0.0	6.374		** Fixed Loss =	6.374	
BFS	349.04	0.0279		0.0	2.220	0.062		Vel =	7.86	
BFS	0.0	4.1	E	14.534	111.470	91.374				
to		140.0	2G	5.813	49.414	1.299				
TEST	349.04	0.0254	T	29.067	160.884	4.087		Vel =	8.48	
	100.00							Qa =	100.00	
	449.04					96.760		K Factor =	45.65	
19	34.46	2.157		0.0	16.000	10.072		K Factor @ node	EQ03	
to		120.0		0.0	0.0	0.0				
20	34.46	0.0107		0.0	16.000	0.171		Vel =	3.03	
20	33.04	2.157		0.0	16.000	10.243		K Factor @ node	EQ04	
to		120.0		0.0	0.0	0.0				
21	67.5	0.0369		0.0	16.000	0.590		Vel =	5.93	
21	33.97	2.157	4E	24.613	47.070	10.833		K Factor @ node	EQ04	
to		120.0	T	12.307	36.920	6.388				
22	101.47	0.0784		0.0	83.990	6.589		Vel =	8.91	
22	2.62	1.682	E	4.95	83.750	23.810				
to		120.0		0.0	4.950	0.0				
23	104.09	0.2761		0.0	88.700	24.491		Vel =	15.03	
23	0.0	1.682	E	4.95	1.630	48.301				
to		120.0	T	9.9	14.850	-0.706				
13	104.09	0.2761		0.0	16.480	4.550		Vel =	15.03	
	0.0							K Factor =	14.41	
	104.09					52.145				
24	20.63	1.049	E	2.0	3.310	12.901		K Factor @ node	EQ02	
to		120.0	T	5.0	7.000	0.0				
25	20.63	0.1378		0.0	10.310	1.421		Vel =	7.66	
25	23.69	1.682		0.0	7.580	14.322				
to		120.0		0.0	0.0	0.0				
26	44.32	0.0570		0.0	7.580	0.432		Vel =	6.40	

Final Calculations - Hazen-Williams

ACCURATE FIRE PROTECTION
 ORCHARD FARMS EARLY CHILDHOOD- AREA B CALC

Page 5
 Date

Hyd. Ref. Point	Qa Qt	Dia. "C" Pf/Ft	Fitting or Eqv.	Ln.	Pipe Ftng's Total	Pt Pe Pf	Pt Pv Pn	*****	Notes	*****
26 to 27	20.95 65.27	1.682 120.0 0.1161		0.0 0.0 0.0	2.850 0.0 2.850	14.754 0.0 0.331			Vel = 9.42	
27 to 28	40.09 105.36	1.682 120.0 0.2824	E	4.95 0.0 0.0	25.940 4.950 30.890	15.085 0.0 8.723		K Factor @ node EQ01	Vel = 15.21	
28 to 29	-2.62 102.74	1.682 120.0 0.2695	T	9.9 0.0 0.0	79.020 9.900 88.920	23.808 0.0 23.966			Vel = 14.83	
29 to 12	0.0 102.74	1.682 120.0 0.2695	E T	4.95 9.9 0.0	1.630 14.850 16.480	47.774 -0.706 4.442			Vel = 14.83	
	0.0 102.74					51.510		K Factor = 14.32		
30 to 4	21.00 21.0	1.049 120.0 0.1425	E T	2.0 5.0 0.0	3.310 7.000 10.310	13.367 0.0 1.469		K Factor @ node EQ02	Vel = 7.80	
	0.0 21.00					14.836		K Factor = 5.45		
31 to 26	20.94 20.94	1.049 120.0 0.1418	E T	2.0 5.0 0.0	3.310 7.000 10.310	13.292 0.0 1.462		K Factor @ node EQ02	Vel = 7.77	
	0.0 20.94					14.754		K Factor = 5.45		
2 to 32	-15.31 -15.31	1.682 120.0 -0.0080		0.0 0.0 0.0	5.150 0.0 5.150	14.312 0.0 -0.041			Vel = 2.21	
32 to 25	39.00 23.69	1.682 120.0 0.0179		0.0 0.0 0.0	2.850 0.0 2.850	14.271 0.0 0.051		K Factor @ node EQ01	Vel = 3.42	
	0.0 23.69					14.322		K Factor = 6.26		
28 to 22	2.62 2.62	1.682 120.0 0.0003		0.0 0.0 0.0	6.070 0.0 6.070	23.808 0.0 0.002			Vel = 0.38	
	0.0 2.62					23.810		K Factor = 0.54		
7 to 33	98.11 98.11	2.157 120.0 0.0737		0.0 0.0 0.0	30.530 0.0 30.530	38.204 0.0 2.250			Vel = 8.61	
33 to 34	-48.03 50.08	2.157 120.0 0.0212		0.0 0.0 0.0	14.000 0.0 14.000	40.454 0.0 0.297			Vel = 4.40	
34 to 35	0.0 50.08	1.682 120.0 0.0713	T	9.9 0.0 0.0	0.620 9.900 10.520	40.751 0.273 0.750			Vel = 7.23	
35 to 36	0.0 50.08	1.682 120.0 0.0713	T 4E	9.9 19.799 0.0	169.270 29.699 198.969	41.774 0.0 14.190			Vel = 7.23	

Final Calculations - Hazen-Williams

ACCURATE FIRE PROTECTION
 ORCHARD FARMS EARLY CHILDHOOD- AREA B CALC

Page 6
 Date

Hyd. Ref. Point	Qa Qt	Dia. "C" Pf/Ft	Fitting or Eqv. Ln.	Pipe Ftng's Total	Pt Pe Pf	Pt Pv Pn	*****	Notes	*****
36 to 37	0.0 50.08	1.682 120.0 0.0713	E T	4.95 9.9 0.0	6.830 14.850 21.680	55.964 -0.706 1.546		Vel = 7.23	
37 to 38	0.0 50.08	2.635 120.0 0.0080		0.0 0.0 0.0	14.910 0.0 14.910	56.804 0.0 0.120		Vel = 2.95	
38 to 14	48.03 98.11	2.635 120.0 0.0278	T	16.474 0.0 0.0	1.360 16.474 17.834	56.924 0.0 0.496		Vel = 5.77	
	0.0 98.11					57.420		K Factor = 12.95	
33 to 39	48.03 48.03	1.682 120.0 0.0660	T	9.9 0.0 0.0	0.620 9.900 10.520	40.454 0.273 0.694		Vel = 6.94	
39 to 40	0.0 48.03	1.682 120.0 0.0660	2T 7E	19.799 34.649 0.0	174.570 54.448 229.018	41.421 0.0 15.121		Vel = 6.94	
40 to 38	0.0 48.03	1.682 120.0 0.0660	E T	4.95 9.9 0.0	1.630 14.850 16.480	56.542 -0.706 1.088		Vel = 6.94	
	0.0 48.03					56.924		K Factor = 6.37	

CONTRACTOR SHALL OVERLAY ALL MECHANICAL SYSTEMS FOR COORDINATION IN ACCORDANCE WITH NFPA 13 GUIDELINES.

CONTRACTOR SHALL ENSURE THAT ALL SPRINKLERS ARE INSTALLED IN ACCORDANCE WITH THE MANUFACTURER'S REQUIREMENTS. (E.G. SPACING WITHIN OFFICE MANUFACTURER'S REQUIREMENTS). ANY CONFLICTS SHALL BE CORRECTED AT CONTRACTOR'S EXPENSE.

CONTRACTOR SHALL VERIFY SPRINKLER MANUFACTURER'S WALL OF ALTERNATE FRAMING TO REACH CEILING SPACE OF ABOVE. CONTRACTOR SHALL COORDINATE SPRINKLER PIPE ROUTING TO SEIZE UPON CEILING SPACE. (SEE ATTACHED DRAWING FOR MORE INFORMATION. CLICK ON ATTACHED IMAGE (ICON) TO VIEW PICTURE OF SPACE).

HYDRAULIC - SYSTEM
TYPE: **PRE-ACTION**
CLASSIFICATION: **CLASS 1**

Building	Project No.	1001
System	System No.	1001
Design	Design No.	1001
Drawn	Drawn No.	1001
Checked	Checked No.	1001
Approved	Approved No.	1001
Date	Date	10/15/13

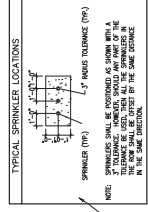

- GENERAL NOTES:**
1. PIPE SIZES AS FOLLOWS:
- 1" FOR 150 GPM TO BE 50M 40 STEEL PIPE
- 1 1/2" FOR 200 GPM TO BE 50M 40 STEEL PIPE
- 2" FOR 250 GPM TO BE 50M 40 STEEL PIPE
- 2 1/2" FOR 300 GPM TO BE 50M 40 STEEL PIPE
 2. ALL PIPE FITTINGS AND HANGERS TO BE IN ACCORDANCE WITH NFPA 13: 2007 AND IBC.
 3. ALL SPRINKLERS TO BE 150 GPM, 1.5" CLASS, TYPICAL, WITH A TOLERANCE OF +/- 1/8".
 4. SPRINKLER SYSTEM TO BE CLASS 1.
 5. ALL PIPING TO BE IN ACCORDANCE WITH NFPA 13: 2007 AND IBC.
 6. ORDER TO PROVIDE ACCURATE HEAT TO PROTECT PIPE FROM FREEZING.

FIRE SPRINKLER PLAN - AREA B
SCALE: 1/8" = 1'-0"

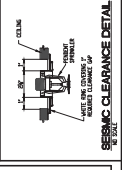
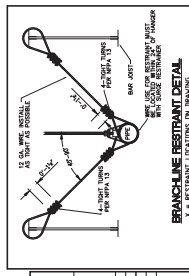
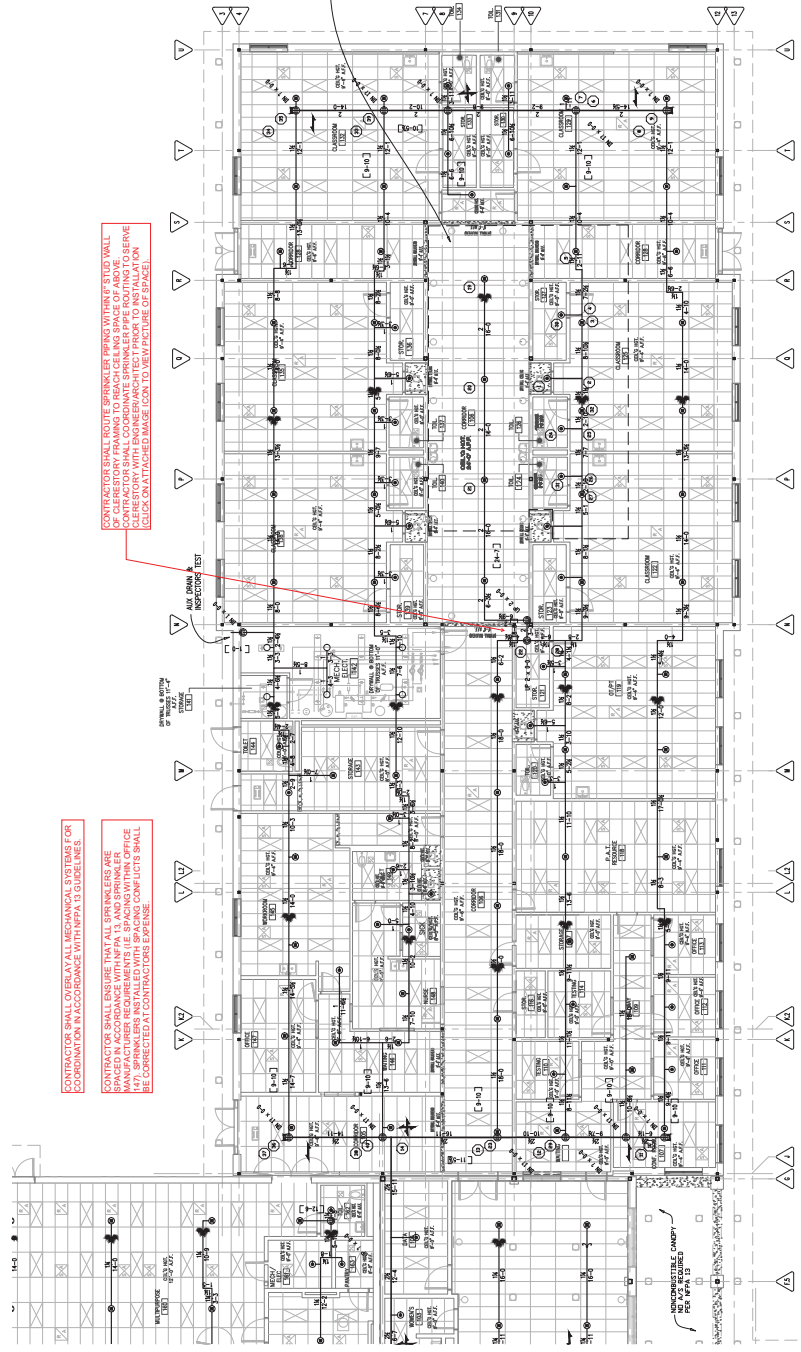
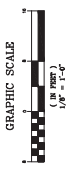

SEISMIC CODE DATA
Seismic Design Category (S.D.C.)

SEISMIC DESIGN CATEGORY	SEISMIC DESIGN CATEGORY (S.D.C.)
II	II

1. Refer to the Seismic Code for the Seismic Design Category (S.D.C.) and the Seismic Design Category (S.D.C.) for the Seismic Design Category (S.D.C.).

2. Refer to the Seismic Code for the Seismic Design Category (S.D.C.) and the Seismic Design Category (S.D.C.) for the Seismic Design Category (S.D.C.).

3. Refer to the Seismic Code for the Seismic Design Category (S.D.C.) and the Seismic Design Category (S.D.C.) for the Seismic Design Category (S.D.C.).

4. Refer to the Seismic Code for the Seismic Design Category (S.D.C.) and the Seismic Design Category (S.D.C.) for the Seismic Design Category (S.D.C.).

5. Refer to the Seismic Code for the Seismic Design Category (S.D.C.) and the Seismic Design Category (S.D.C.) for the Seismic Design Category (S.D.C.).

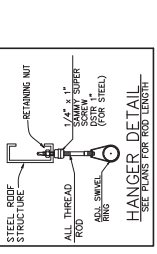
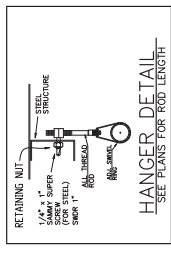
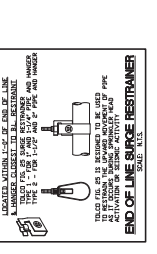
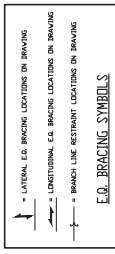
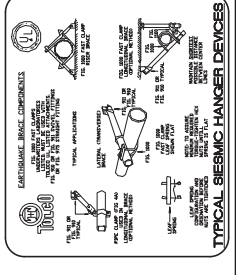
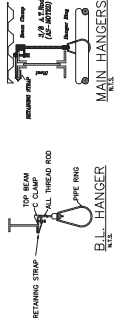
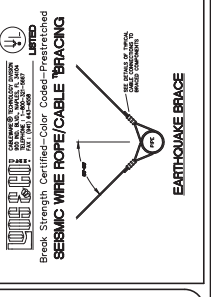

Accurate
Fire Protection Systems, LLC

1428 Crocus Rd. High Ridge, Mo. 63049
PHONE: (636) 677-9190 FAX: (636) 677-9191

PROJECT: ORCHARD FARM
EARLY CHILDHOOD COMPLEX
3405 BUCKINGHAM BLVD. WINDSOR PARK
ST. CHARLES, MO. 63073

DATE: 10/15/13
PAGE: 2 OF 2

SUBMITTALS OF REVISIONS

NO.	DATE	COMMENTS
1		
2		
3		
4		
5		
6		
7		
8		
9		
10		
11		
12		
13		
14		
15		
16		
17		
18		
19		
20		
21		
22		
23		
24		
25		
26		
27		
28		
29		
30		
31		
32		
33		
34		
35		
36		
37		
38		
39		
40		
41		
42		
43		
44		
45		
46		
47		
48		
49		
50		
51		
52		
53		
54		
55		
56		
57		
58		
59		
60		
61		
62		
63		
64		
65		
66		
67		
68		
69		
70		
71		
72		
73		
74		
75		
76		
77		
78		
79		
80		
81		
82		
83		
84		
85		
86		
87		
88		
89		
90		
91		
92		
93		
94		
95		
96		
97		
98		
99		
100		

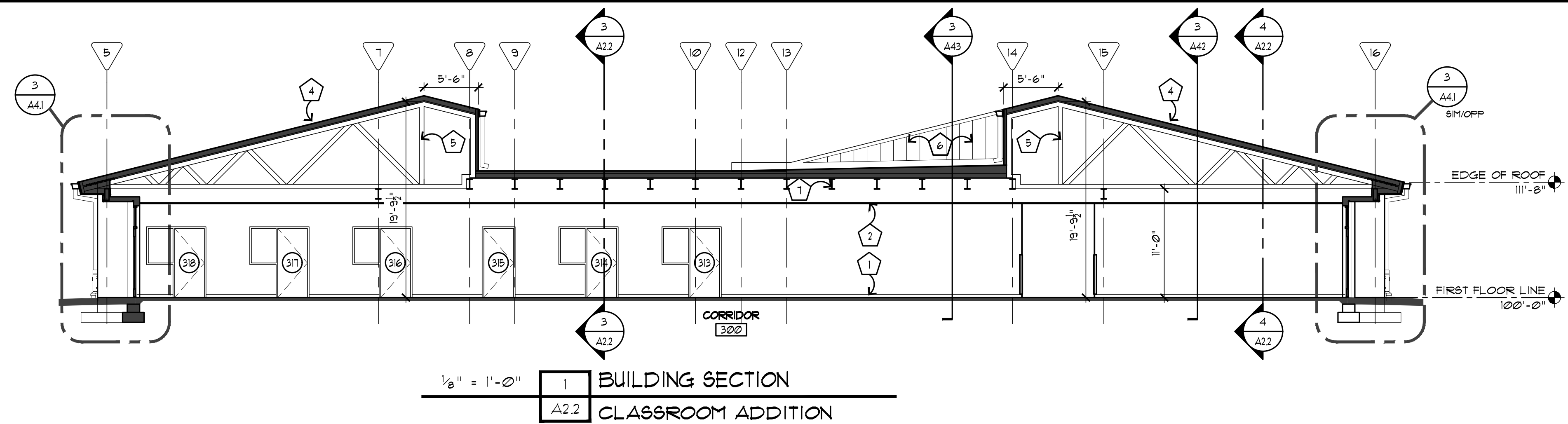

- ### KEYED NOTES
- 1 WALL BASE, SEE ROOM MATERIAL SCHEDULE 4 SPECS.
 - 2 ACOUSTICAL CEILING TILE, SEE ROOM MATERIAL SCHEDULE AND SPECIFICATIONS.
 - 3 ADJ. SHELVING - SEE DA MANUAL - DIVISION 12.
 - 4 ASPHALT SHINGLE ROOF OVER ICE & WATER SHIELD ON 1/2" FIRE TREATED PLYWOOD SHEATHING ALL OVER 3" RIGID INSULATION (2 LAYERS AT CONTR. OPTION) ON 1/2" METAL DECK. SEE SPECS & STRUCT. DRAWINGS.
 - 5 LIGHT GAUGE STEEL TRUSSES - SEE STRUCTURAL.
 - 6 PRE-FINISHED METAL SIDING & TRIM SEE DA MANUAL - DIVISION 1.
 - 7 STEEL BEAM JOIST, SEE STRUCTURAL DRAWINGS.

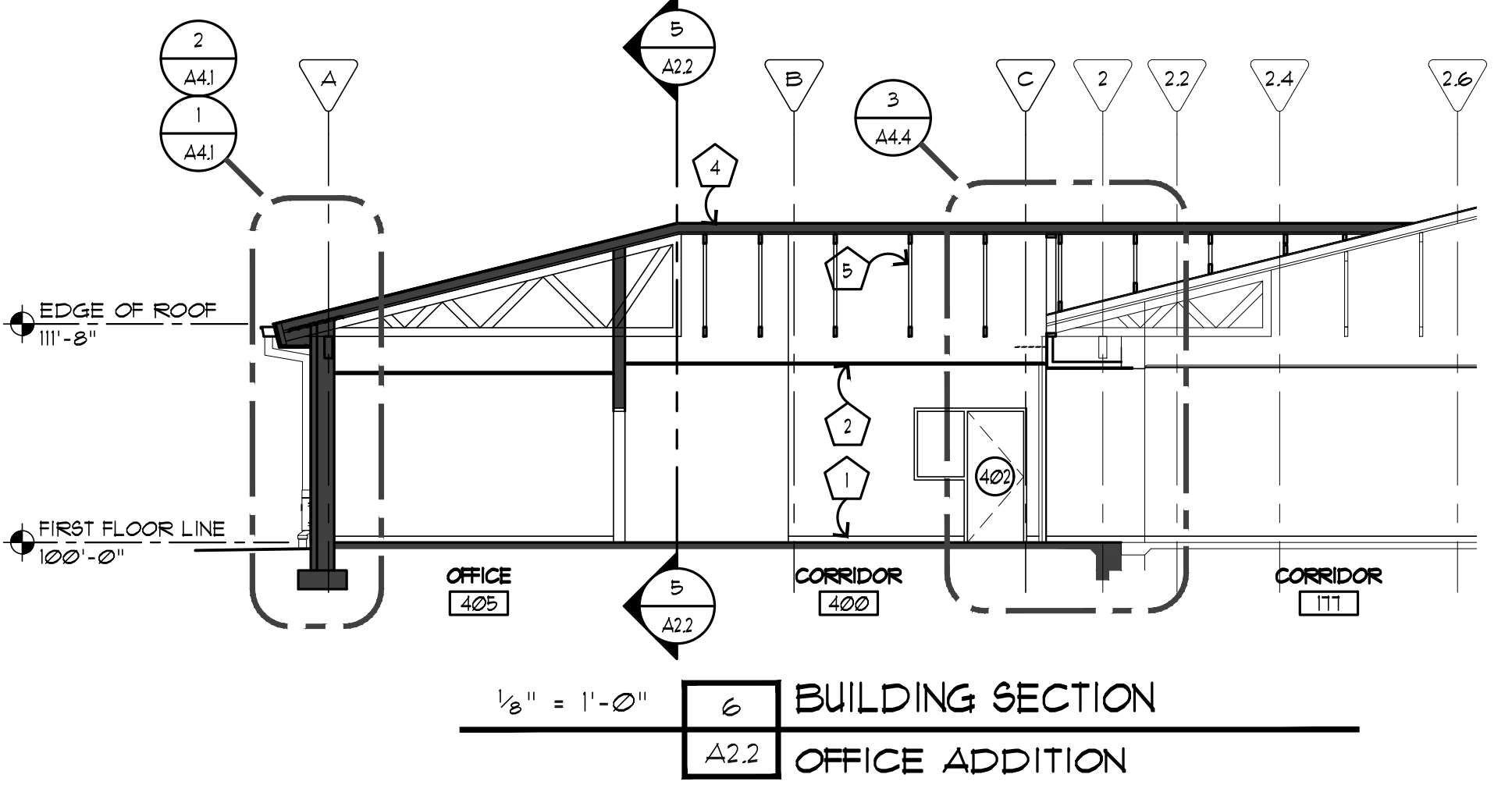
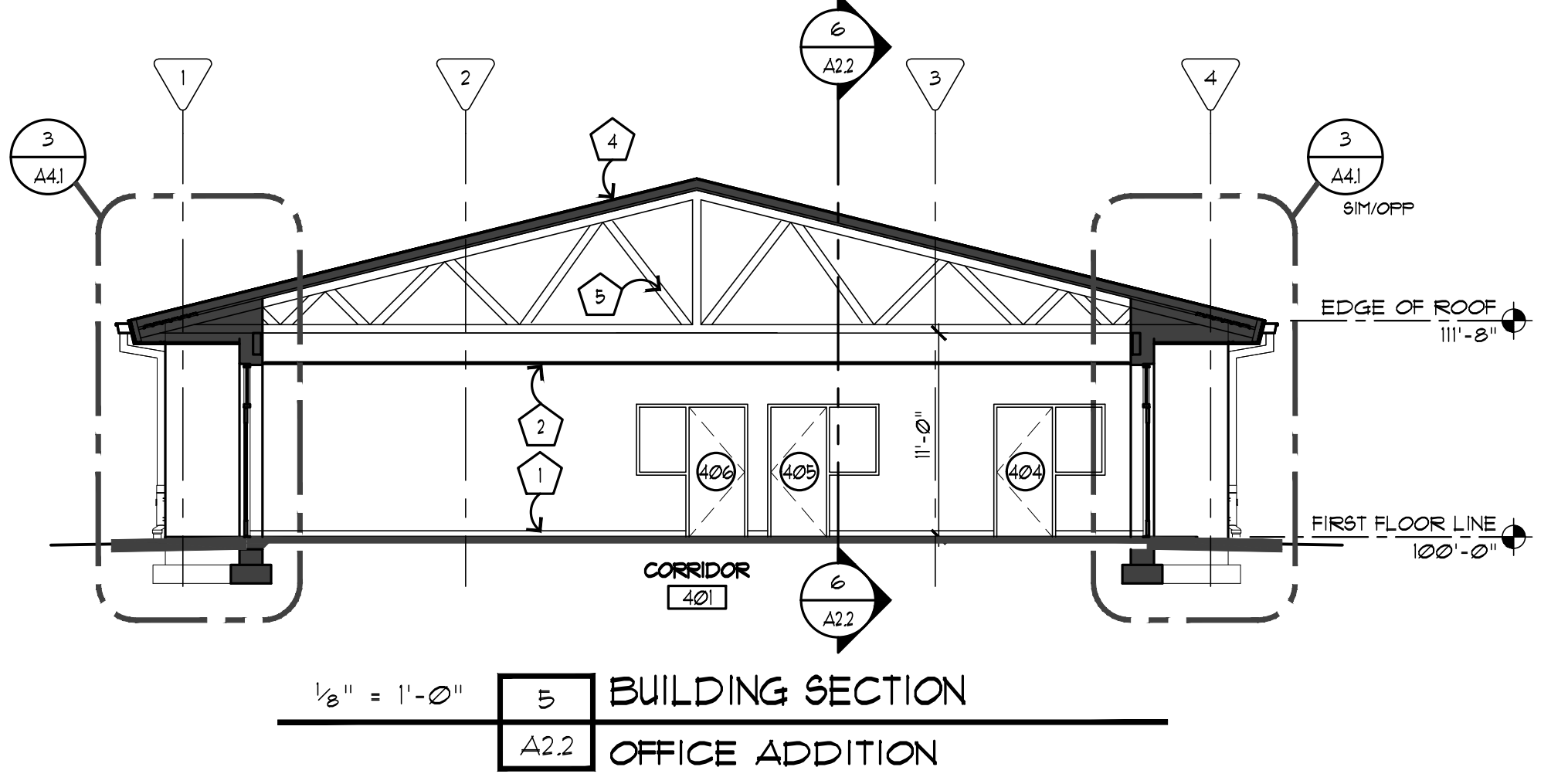
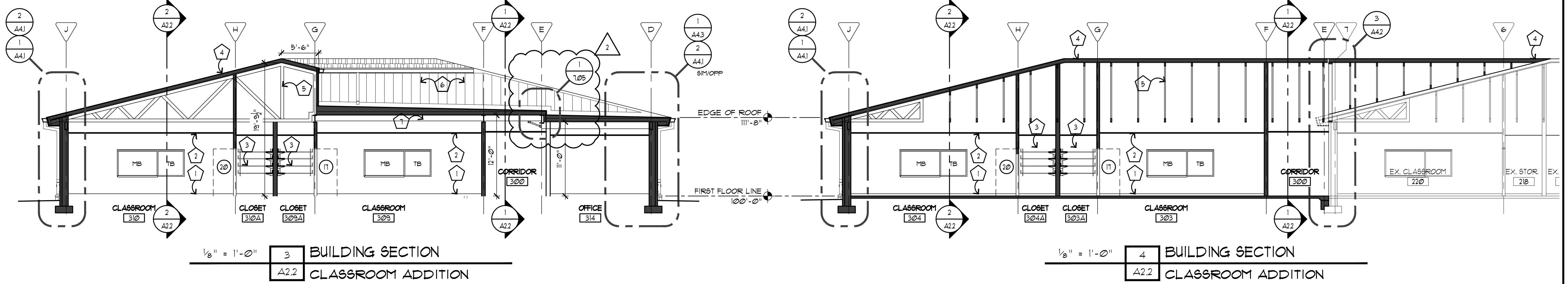
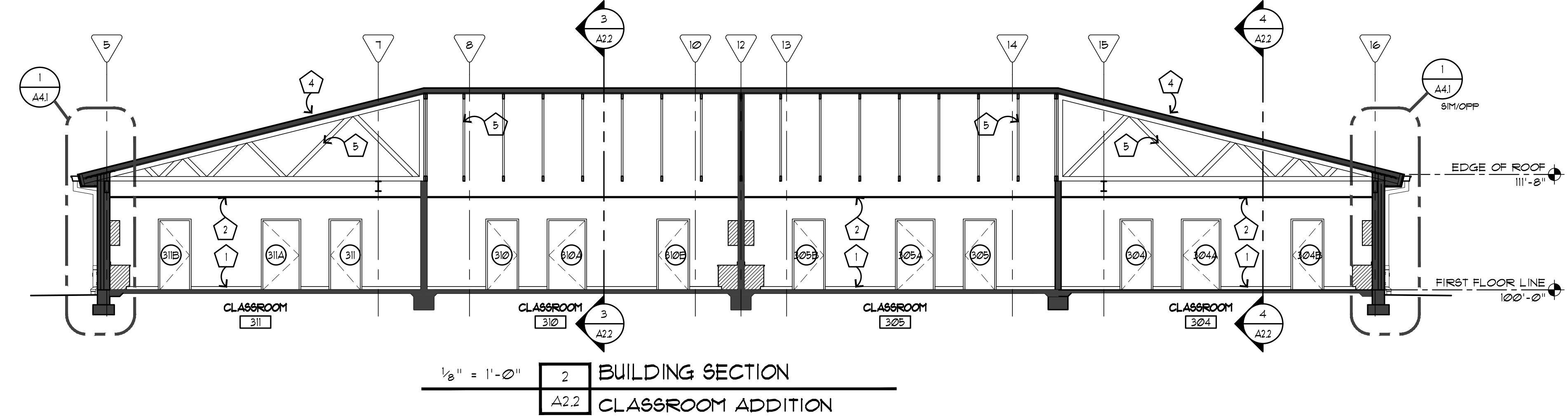

GENERAL CONTRACTOR SHALL BE RESPONSIBLE FOR COORDINATING MECHANICAL PLANS WITH TRUSS SUPPLIER TO ENSURE DUCTWORK, AS DESIGNED (SEE MECH.), IS ACCOMMODATED BY THE TRUSS DESIGN. DUCTWORK SHOWN ON BUILDING SECTIONS IS GRAPHIC REPRESENTATION ONLY AND DOES NOT REPRESENT FINAL DESIGN.

SCHEDULES AND DETAILS ARE LOCATED ON SHEETS DESIGNATED 'DA' WHICH ARE BOUND SEPARATE FROM THE PROJECT SPECIFICATIONS.

ADDITIONS AND RENOVATIONS TO:
EARLY LEARNING CENTER
 3489 BOSCHERTOWN ROAD AND ISLAND HARBOR DRIVE
 ORCHARD FARM R-V SCHOOL DISTRICT ST. CHARLES COUNTY, MISSOURI

MARK A. REUTHER
 LICENSE #006452
 ARCHITECTURAL CORP.
 NO. 000193

HOENER ASSOCIATES, INC. - ARCHITECTS
 6707 PLAINVIEW AVENUE
 ST. LOUIS, MISSOURI 63109
 Ph. (314) 781-9855

CONSULTING ENGINEERS:
 BAX ENGINEERING
 ASDG
 CIVIL/SURVEY
 STRUCTURAL
 MECH/ELEC/PLUMB
 MCCLURE ENGINEERING

ALL DIMENSIONS MUST BE VERIFIED AT BUILDING BEFORE WORK IS EXECUTED. THIS DRAWING IS THE PROPERTY OF THE ARCHITECTS AND SHALL NOT BE COPIED OR DUPLICATED WITHOUT THEIR CONSENT.

proj. no. 23-09C
 date issued
 JULY 02, 2024
 date revised
 ADD#2 08/01/24

drawn by **BF**
 checked by **MR**
 sheet no.

A2.2
 SD-11

File: S:\104306.004 OFSD ELC ADDITIONS 2024\03 MECHANICAL\M3-1\M3.2-104306.004 Saved: 2024-7-31 11:23 By: Jsnyder

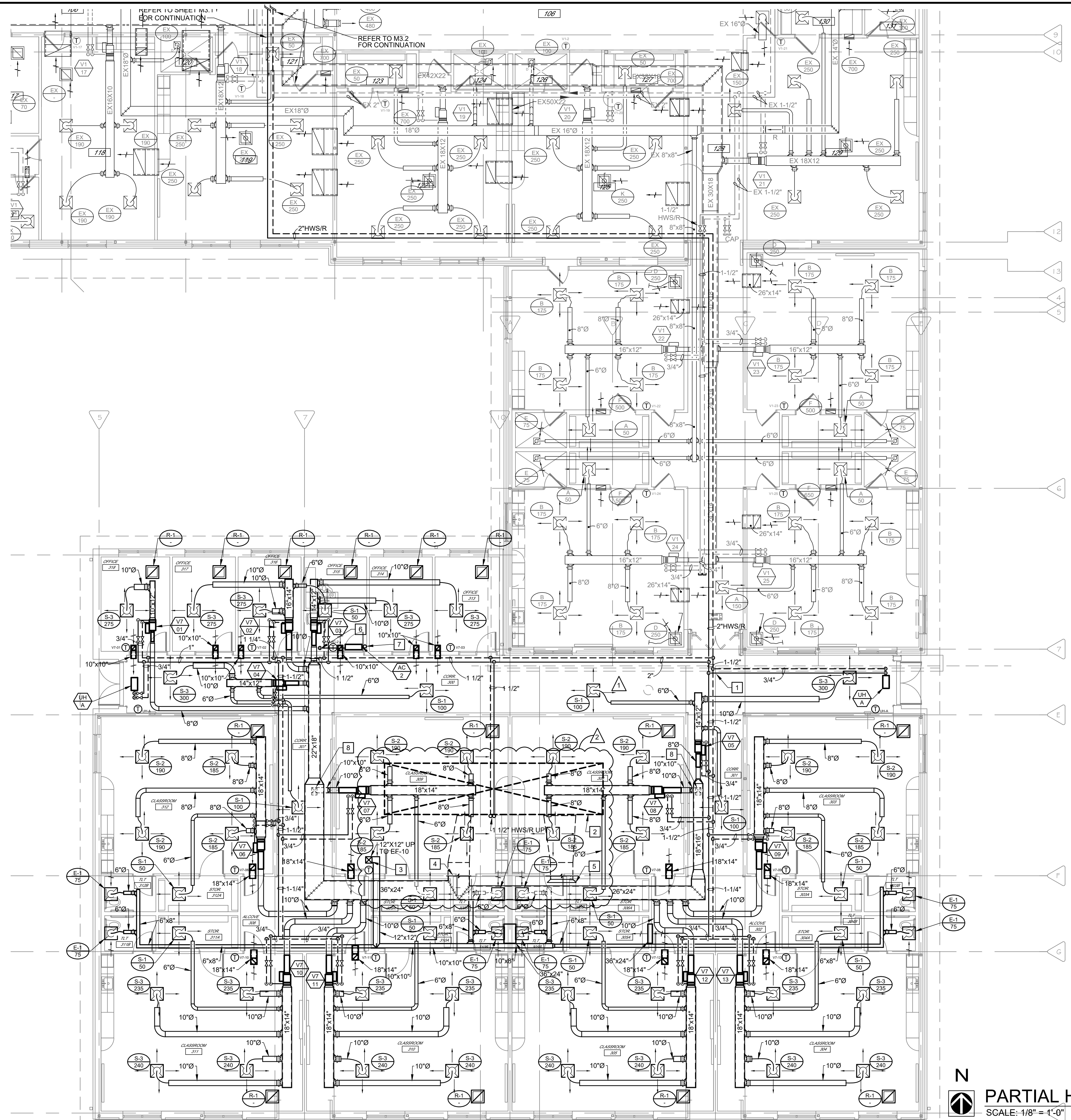

- KEYED NOTES**
- 1 NEW 2" PIPING TO SERVE HW COIL AT RTU, UNIT HEATERS ABOVE ENTRY DOORS, AND VAV REHEAT COILS.
 - 2 NEW RTU-7 ON ROOF ABOVE TO SERVE NEW ADDITION, INDICATED AS DASHED FOR REFERENCE.
 - 3 NEW EXHAUST FAN SHALL BE PROVIDED FOR TOILET EXHAUST. REFER TO ROOF PLAN.
 - 4 REFER TO SHEET M3.3 FOR SA/RA DUCT SIZING AND CONTINUATION ABOVE ROOF.
 - 5 RETURN AIR INTAKE WITH BELLMOUTH OPENING ABOVE CEILING.
 - 6 3/4" CONDENSATE DRAIN FROM AC-2 TO DRAIN.
 - 7 GAS AND LIQUID REFRIGERANT PIPING FROM AC-2 UP TO CONDENSING UNIT ON ROOF.
 - 8 TAP OFF BOTTOM OF DUCT MAIN WITH MITERED ELBOW, TRANSITION TO ROUND AND EXTEND INTO CLASSROOM SPACE ABOVE CEILING.

PARTIAL HVAC NEW WORK PLAN
SCALE: 1/8" = 1'-0"

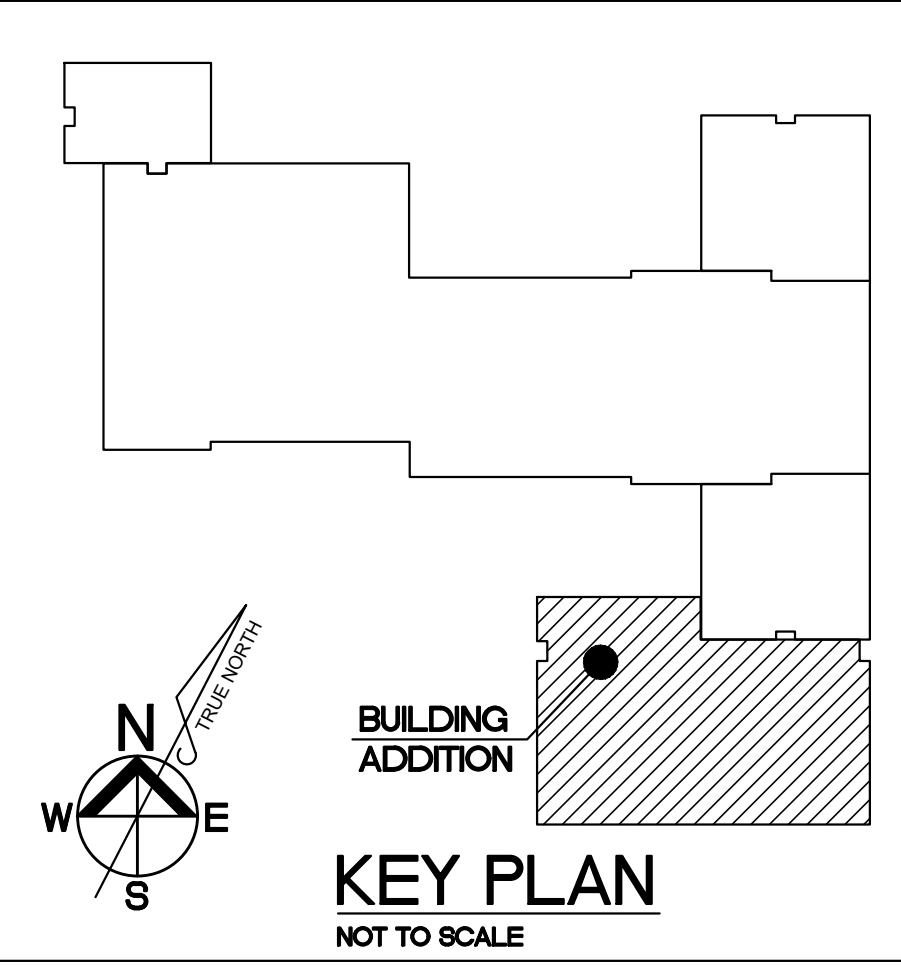

ALEX PUGH
LICENSE #2011015789
ENGINEERING CORP.
NO. 000087

ADDITIONS AND RENOVATIONS TO:
EARLY LEARNING CENTER
3489 BOSCHERTOWN ROAD and ISLAND HARBOR DRIVE
ORCHARD FARM R-V SCHOOL DISTRICT
ST. CHARLES COUNTY, MISSOURI

CONSULTING ENGINEERS:
BAX ENGINEERING
ASDG
McCLURE ENGINEERING
CIVIL/SURVEY
STRUCTURAL
MECH/ELEC/PLUMB

ARCHITECTS
HOENER ASSOCIATES, INC.
6707 PLAINVIEW AVENUE
ST. LOUIS, MISSOURI 63109
Ph. (314) 781-9855

ALL DIMENSIONS MUST BE VERIFIED AT BUILDING BEFORE WORK IS EXECUTED. THIS DRAWING IS THE PROPERTY OF THE ARCHITECTS AND SHALL NOT BE COPIED OR DUPLICATED WITHOUT THEIR CONSENT.

proj. no. 23-09C
date issued 07 02 2024
date revised
1 ADD#1 07/23/2024
2 ADD#2 08/01/2024

drawn by JWS
checked by KG
sheet no.

M3.1
SD-12

File: S:\104306.004 OFSD ELC ADDITIONS 2024\03 MECHANICAL\M3.3-104306.004 Saved: 2024-7-31 11:28 By: jsnyder

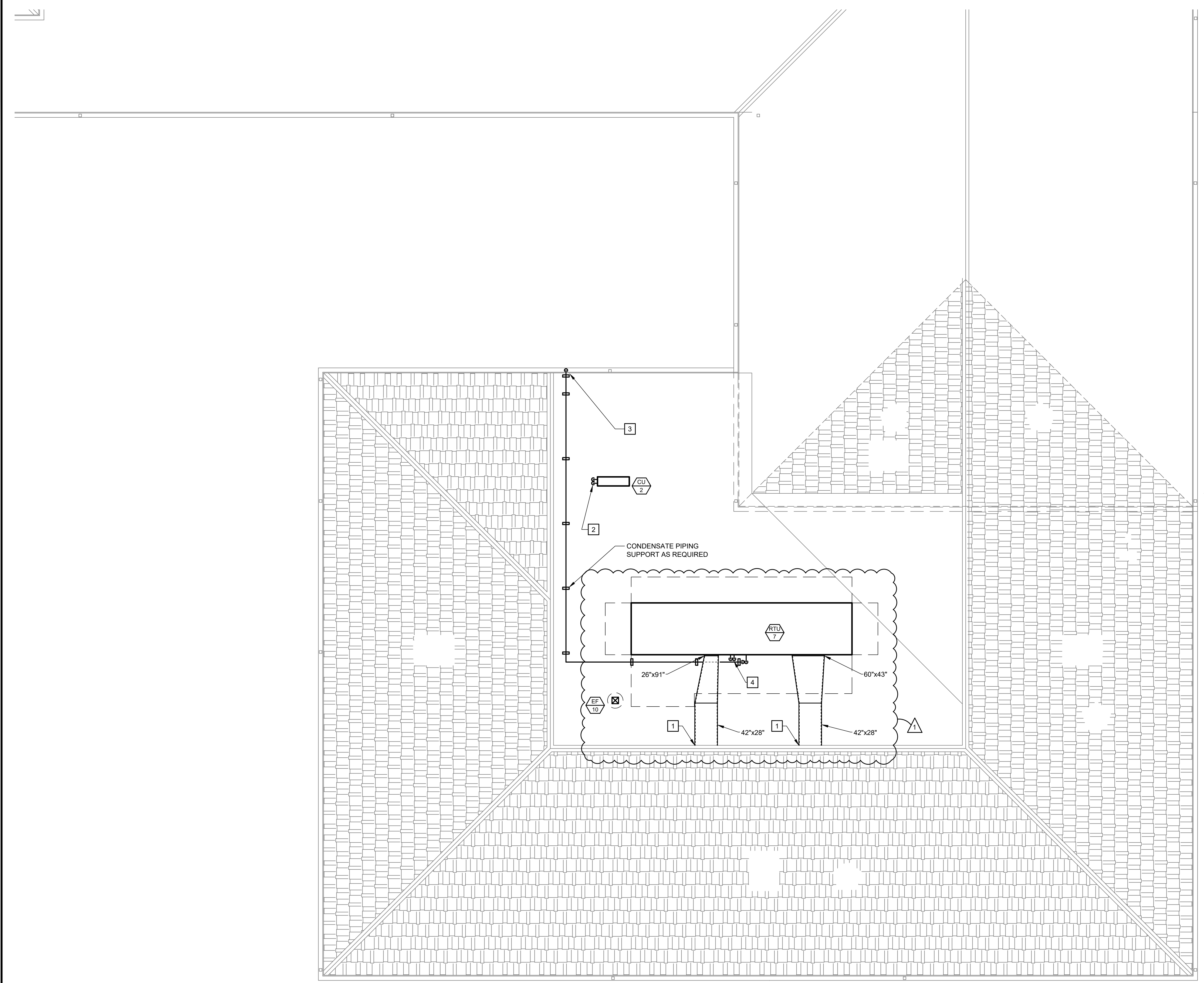

GENERAL NOTES

1. FURNISH AND INSTALL SUPPLY STOP SHUT-OFF VALVES ON ALL FIXTURE WATER SUPPLY LINES. FURNISH AND INSTALL WATER HAMMER ARRESTORS PER PDI W4201 AND AS INDICATED ON DRAWINGS. INSTALL VALVES IN ACCESSIBLE LOCATIONS. IF LOCATION IS NOT READILY ACCESSIBLE, COORDINATE ACCESS PANEL REQUIREMENTS WITH GENERAL CONTRACTOR.
2. ALL PIPING SHALL BE CONCEALED IN CHASE, WALL, CEILING, FLOORING, ETC. UNLESS OTHERWISE NOTED. PIPING SHOWN OUTSIDE OF WALL FOR CLARITY ONLY.
3. EQUIPMENT AND FIXTURE SYMBOLOLOGY ON PLANS MAY NOT REFLECT ACTUAL TYPE. REFER TO SPECIFICATIONS AND SCHEDULES FOR FIXTURE OR EQUIPMENT TYPE.
4. LOCATIONS OF FLOOR DRAINS, FLOOR SINKS, TRENCH DRAINS, ETC. INDICATED ON THESE DRAWINGS ARE CONSIDERED APPROXIMATE. THIS CONTRACTOR SHALL BE RESPONSIBLE FOR COORDINATION OF FINAL AND EXACT LOCATIONS WITH ALL OTHER TRADES AND EQUIPMENT SUPPLIERS PRIOR TO INSTALLATION. DRAINS, ETC. NOT CORRECTLY LOCATED AS DETERMINED BY THE ARCHITECT/ENGINEER/OWNER, SHALL BE REMOVED AND RELOCATED AT THIS CONTRACTOR'S EXPENSE.
5. WHERE A NEW FLOOR DRAIN/FLOOR SINK IS BEING INSTALLED IN AN EXISTING FLOOR SLAB, A 48"X48" SECTION OF THE SLAB SHALL BE REMOVED AND POURED BACK, SLOPING TO THE NEW DRAIN.

KEYED NOTES

- 1 PROVIDE 2'-2" ANGLE AT DUCT PENETRATIONS OF VERTICAL WALL. COMPLETELY SEAL PENETRATION WATER TIGHT.
- 2 REFRIGERANT LINES DN. THROUGH ROOF TO AC-2.
- 3 1-1/2" CONDENSATE PIPE ON PIPING SUPPORTS AS REQUIRED, SPILL TO GUTTER.
- 4 HWS/R PIPING DN. THROUGH ROOF.

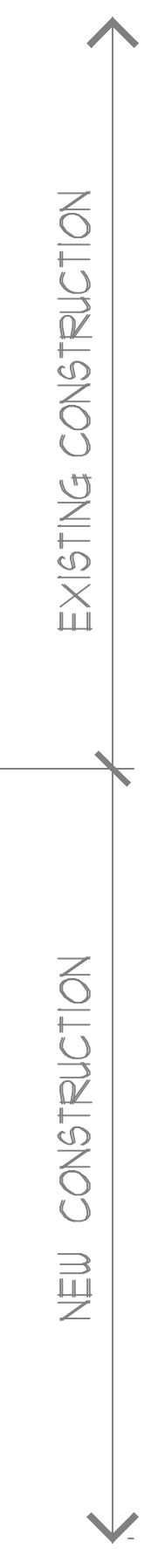

PARTIAL HVAC NEW WORK ROOF PLAN
 SCALE: 1/8" = 1'-0"

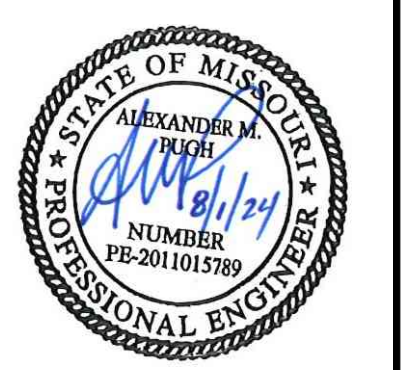
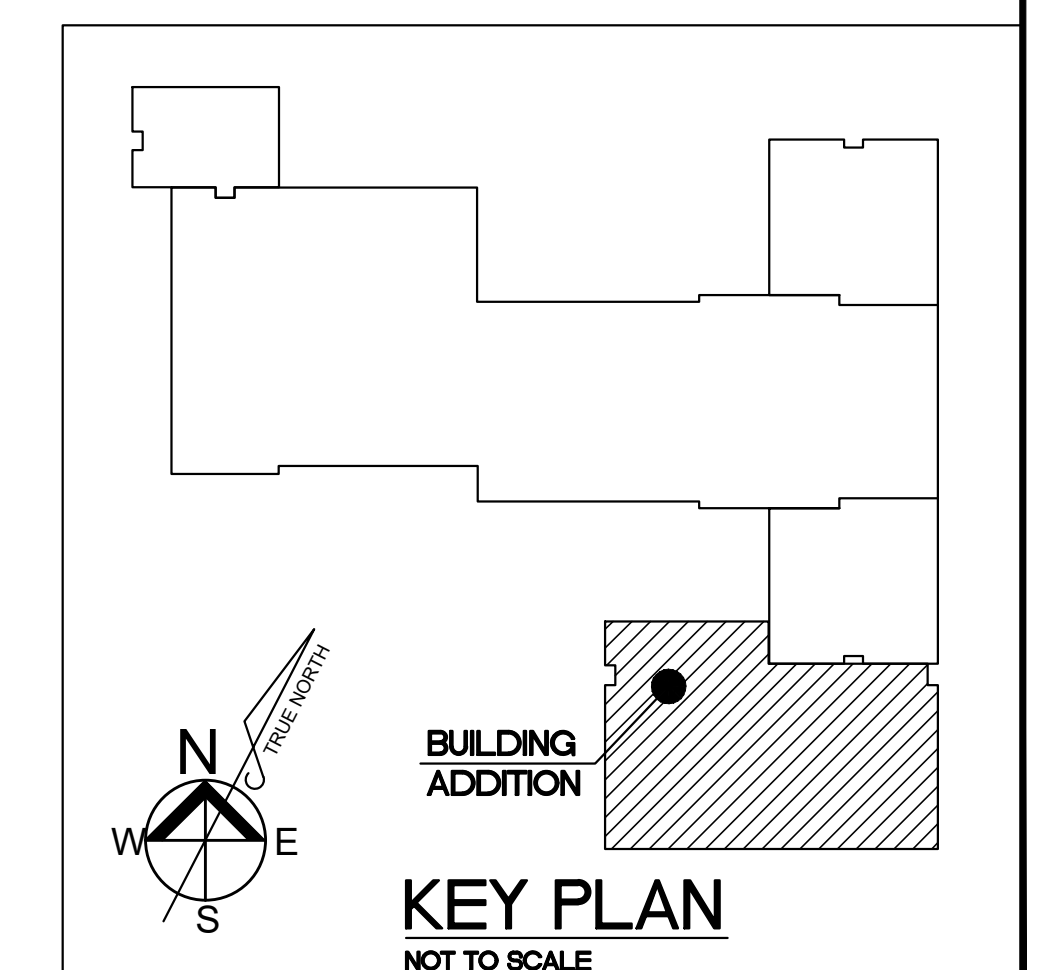

ALEX PUGH
 LICENSE #2011015789
 ENGINEERING CORP.
 NO. 00087

ADDITIONS AND RENOVATIONS TO:
EARLY LEARNING CENTER
 3489 BOSCHERTOWN ROAD and ISLAND HARBOR DRIVE
 ST. CHARLES COUNTY, MISSOURI
 ORCHARD FARM P-V SCHOOL DISTRICT

HOENER ASSOCIATES, INC. - ARCHITECTS
 6707 PLAINVIEW AVENUE
 ST. LOUIS, MISSOURI 63109
 Ph. (314) 781-9855

CONSULTING ENGINEERS:
 BAX ENGINEERING
 ASDG
 McCLURE ENGINEERING

**CIVIL/SURVEY
 STRUCTURAL
 MECH/ELEC/PLUMB**

ALL DIMENSIONS MUST BE VERIFIED AT BUILDING BEFORE WORK IS EXECUTED. THIS DRAWING IS THE PROPERTY OF THE ARCHITECTS AND SHALL NOT BE COPIED OR DUPLICATED WITHOUT THEIR CONSENT.

proj. no. 23-09C
 date issued 07 02 2024
 date revised
 1 ADD#2 08/01/2024

drawn by RCB
 checked by KG
 sheet no.

M3.3
 SD-13

Fig. S:\104306.004 OFSD ELC ADDITIONS 2024\03 ELECTRICAL\E4.1-E4.2-104306.004 Saved: 2024-8-1 10:53 By: Nmak

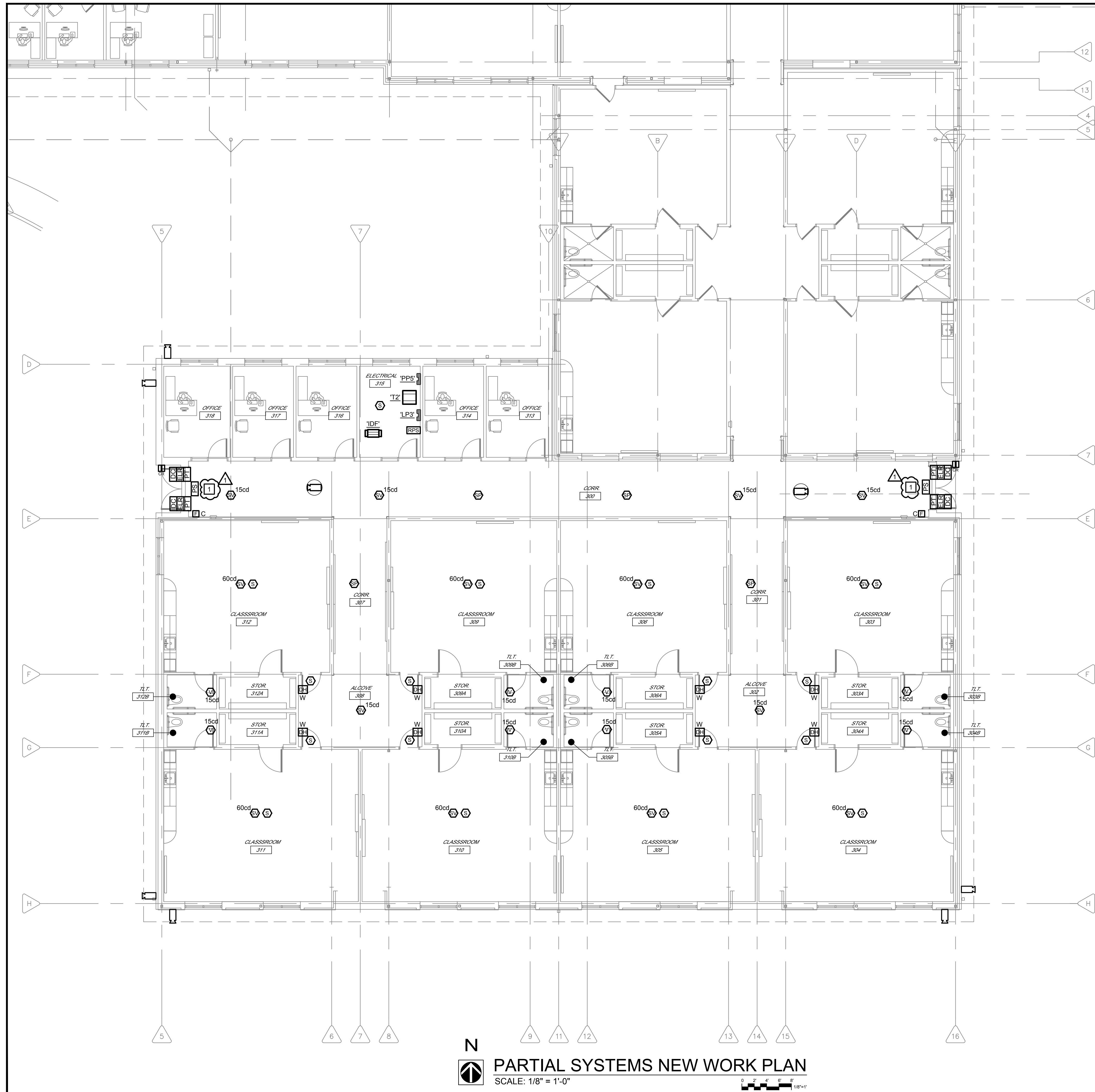

PARTIAL SYSTEMS NEW WORK PLAN
SCALE: 1/8" = 1'-0"

- GENERAL NOTES**
- TEMPORARILY SUPPORT ALL FIRE ALARM DEVICES DURING CONSTRUCTION.
 - ALL FIRE ALARM CABLING TO BE PLENUM RATED.
 - FIRE ALARM DEVICES TO BE PROGRAMMED WITH FINAL ROOM NUMBERS.
 - COORDINATE INSTALLATION OF FIRE ALARM SMOKE DETECTORS SUCH THAT THEY ARE INSTALLED AT A MINIMUM OF 36" AWAY FROM MECHANICAL SUPPLY AIR GRATES.
 - ALL FIRE ALARM CABLING EXPOSED TO BE INSTALLED IN CONDUIT.
 - ALL DATA AND LOW VOLTAGE SYSTEMS CABLING TO BE SUPPORTED BY J-HOOKS OR CABLE TRAY INSTALLED AT A READILY ACCESSIBLE HEIGHT ABOVE CEILING, UNLESS NOTED TO BE IN CONDUIT. ROUTE IN CORRIDOR WHERE POSSIBLE.
 - SECURITY CAMERAS ARE OWNER FURNISHED, OWNER INSTALLED. ELECTRICAL CONTRACTOR SHALL PROVIDE DATA JACK WHERE CAMERA SYMBOLS ARE SHOWN.
 - DEVICE AND NAMEPLATE COLOR SHALL BE WHITE UNLESS OTHERWISE NOTED OR DIRECTED BY ARCHITECT OR OWNER.
 - NEW FIRE ALARM DEVICES TO BE TIED TO THE EXISTING FIRE ALARM CONTROL PANEL IN DATA 204.
 - EXISTING DOOR ACCESS CONTROLS SHALL BE RECONFIGURED TO PROPERLY FUNCTION WITH THE NEW HARDWIRED S2 SYSTEM. PROVIDE NEW REMOTE-MOUNTED CARD READERS FOR ALL LOCATIONS AND REITERMINATE EXISTING DATA CABLING. COORDINATE WITH LOW VOLTAGE VENDOR AND OWNER PRIOR TO INSTALLATION.

- KEYED NOTES**
- NEW EXTERIOR ACCESS CONTROLS SHALL BE HARDWIRED AND CONNECTED TO THE DOOR ACCESS CONTROLS PANEL LOCATED IN RM. 104. CONTRACTOR SHALL COORDINATE WITH OWNER PRIOR TO INSTALLATION.

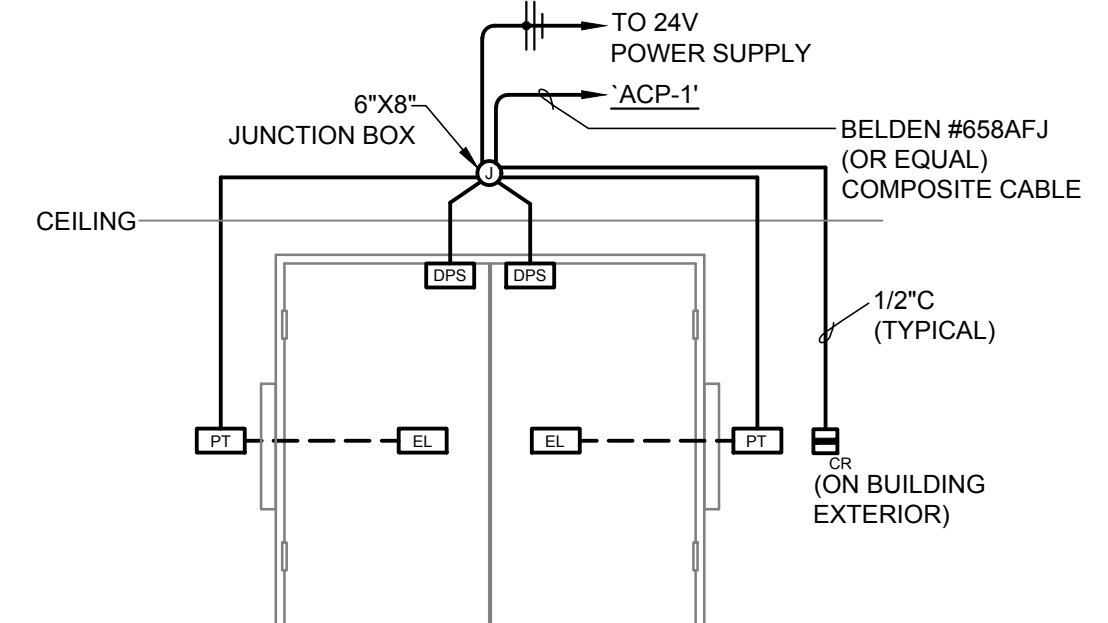

TYPICAL ACCESS CONTROL ELEVATION

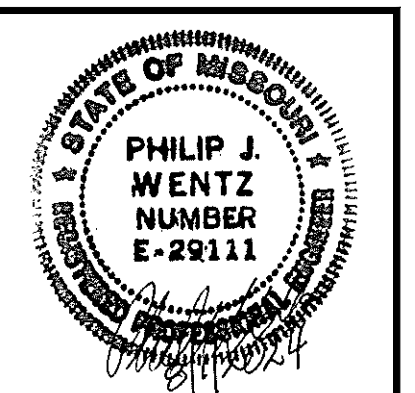
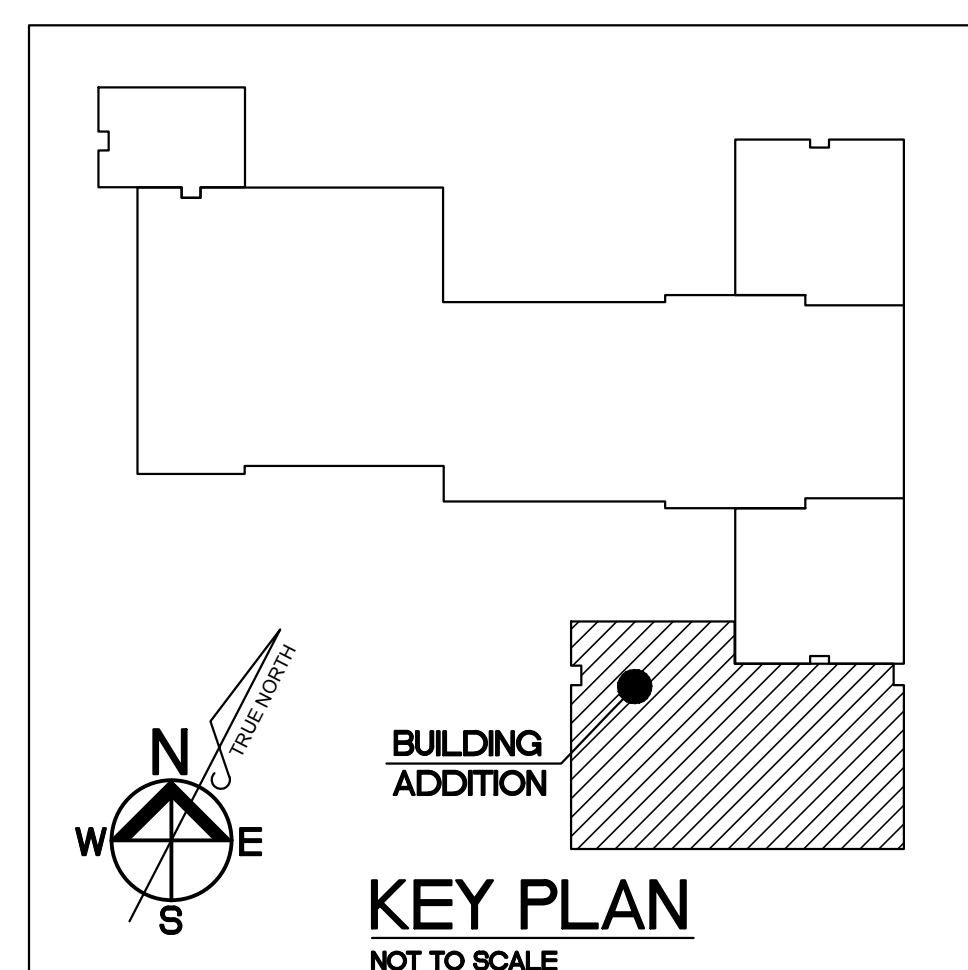

PHIL WENTZ
LICENSE #E-2911
ENGINEERING CORP.
NO. 00087

ADDITIONS AND RENOVATIONS TO:
EARLY LEARNING CENTER
3489 BOSCHERTOWN ROAD and ISLAND HARBOR DRIVE
ST. CHARLES COUNTY, MISSOURI
ORCHARD FARM R-V SCHOOL DISTRICT

CONSULTING ENGINEERS:
CIVIL/SURVEY
STRUCTURAL
MECH/ELEC/PLUMB
BAX ENGINEERING
ASDC
McCLURE ENGINEERING

ARCHITECTS
HOENER ASSOCIATES, INC. - ARCHITECTS
6707 PLAINVIEW AVENUE
ST. LOUIS, MISSOURI 63109
Ph. (314) 781-9855

ALL DIMENSIONS MUST BE VERIFIED AT BUILDING BEFORE WORK IS EXECUTED. THIS DRAWING IS THE PROPERTY OF THE ARCHITECTS AND SHALL NOT BE COPIED OR DUPLICATED WITHOUT THEIR CONSENT.

proj. no. 23-09C
date issued 07 02 2024
date revised 1 ADD#2 08/01/2024

drawn by NAM
checked by RAJ
sheet no.

E4.1
SD-14

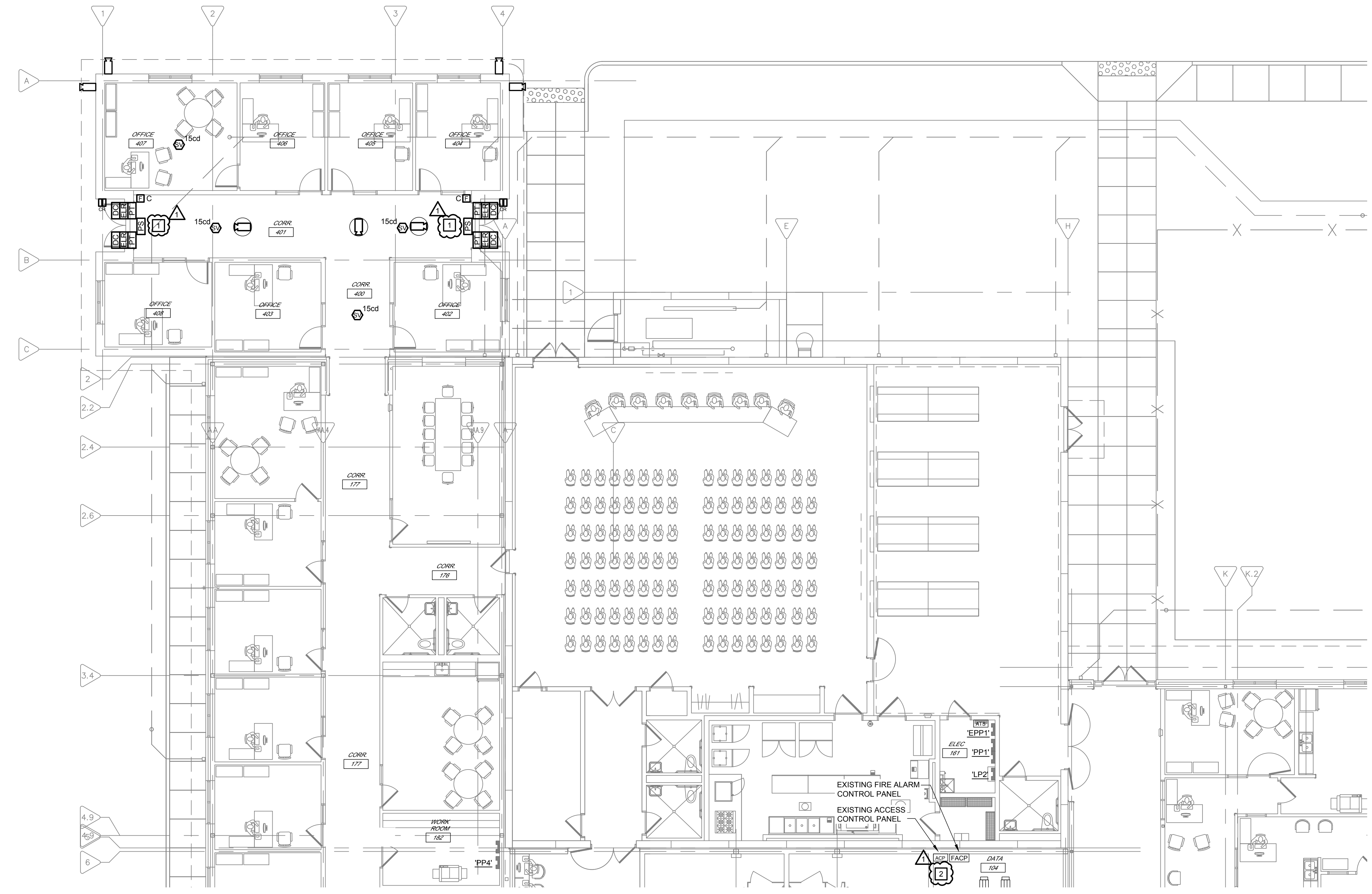

PARTIAL SYSTEMS NEW WORK PLAN - ALTERNATE #1
 SCALE: 1/8" = 1'-0"

GENERAL NOTES

1. TEMPORARILY SUPPORT ALL FIRE ALARM DEVICES DURING CONSTRUCTION.
2. ALL FIRE ALARM CABLING TO BE PLENUM RATED.
3. FIRE ALARM DEVICES TO BE PROGRAMMED WITH FINAL ROOM NUMBERS.
4. COORDINATE INSTALLATION OF FIRE ALARM SMOKE DETECTORS SUCH THAT THEY ARE INSTALLED AT A MINIMUM OF 36" AWAY FROM MECHANICAL SUPPLY AIR GRATES.
5. ALL FIRE ALARM CABLING EXPOSED TO BE INSTALLED IN CONDUIT.
6. ALL DATA AND LOW VOLTAGE SYSTEMS CABLING TO BE SUPPORTED BY J-HOOKS OR CABLE TRAY INSTALLED AT A READILY ACCESSIBLE HEIGHT ABOVE CEILING, UNLESS NOTED TO BE IN CONDUIT. ROUTE IN CORRIDOR WHERE POSSIBLE.
7. SECURITY CAMERAS ARE OWNER FURNISHED, OWNER INSTALLED. ELECTRICAL CONTRACTOR SHALL PROVIDE DATA JACK WHERE CAMERA SYMBOLS ARE SHOWN.
8. DEVICE AND NAMEPLATE COLOR SHALL BE WHITE UNLESS OTHERWISE NOTED OR DIRECTED BY ARCHITECT OR OWNER.
9. NEW FIRE ALARM DEVICES TO BE TIED TO THE EXISTING FIRE ALARM CONTROL PANEL IN DATA 104.
10. EXISTING DOOR ACCESS CONTROLS SHALL BE RECONFIGURED TO PROPERLY FUNCTION WITH THE NEW HARDWIRED S2 SYSTEM. PROVIDE NEW REMOTE-MOUNTED CARD READERS FOR ALL LOCATIONS AND DETERMINATE EXISTING DATA CABLING. COORDINATE WITH LOW VOLTAGE VENDOR AND OWNER PRIOR TO INSTALLATION.

KEYED NOTES

- 1 NEW EXTERIOR ACCESS CONTROLS SHALL BE HARDWIRED AND CONNECTED TO THE DOOR ACCESS CONTROLS PANEL LOCATED IN RM. 104. CONTRACTOR SHALL COORDINATE WITH OWNER PRIOR TO INSTALLATION.
- 2 CONTRACTOR TO COORDINATE WITH OWNER ON NECESSITY OF UPGRADE TO EXISTING ACCESS CONTROL SYSTEM MAIN CPU DUE TO ADDITION OF EXISTING AND NEW DOORS TO THE HEAD-END EQUIPMENT.

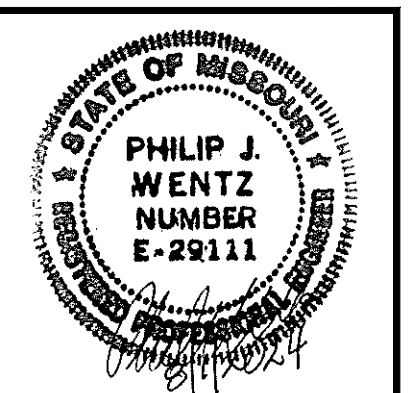
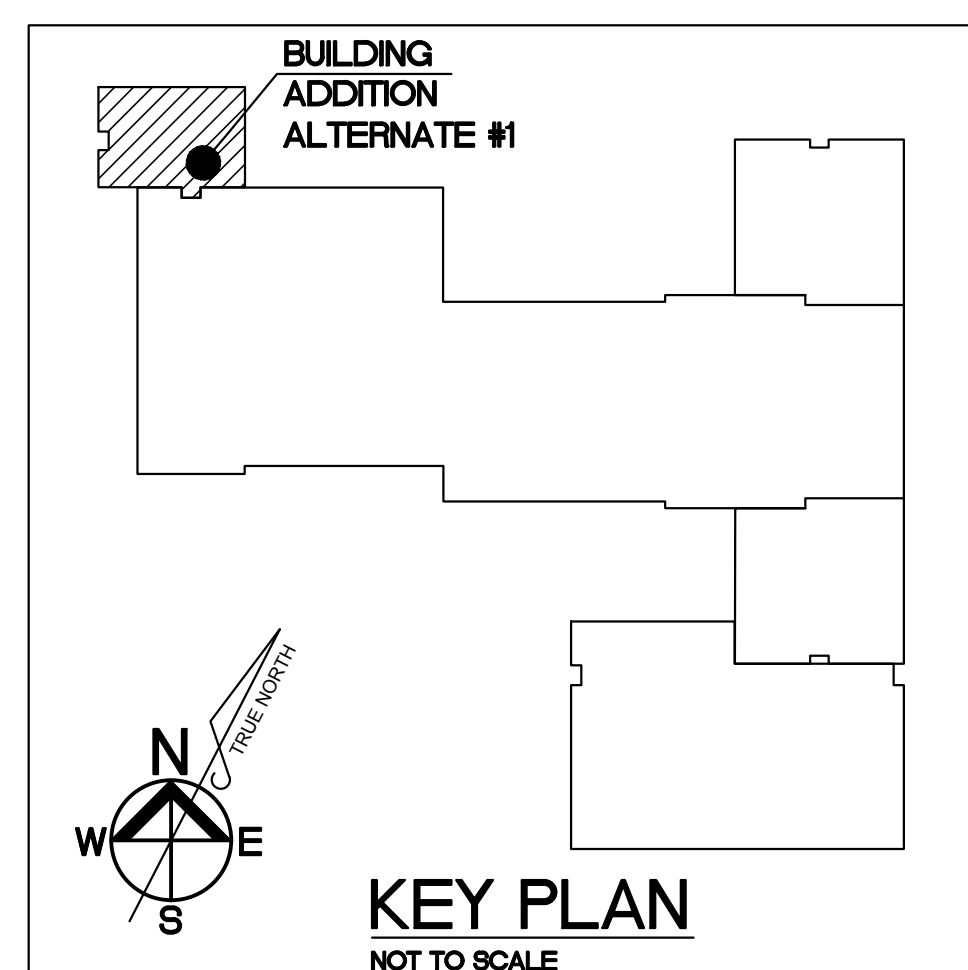

PHIL WENTZ
 LICENSE #E-2911
 ENGINEERING CORP.
 NO. 000087

ADDITIONS AND RENOVATIONS TO:
EARLY LEARNING CENTER
 3489 BOSCHERTOWN ROAD and ISLAND HARBOR DRIVE
 ORCHARD FARM R-V SCHOOL DISTRICT
 ST. CHARLES COUNTY, MISSOURI

CONSULTING ENGINEERS:
 BAX ENGINEERING
 ASDG
 McCLURE ENGINEERING
 CIVIL/SURVEY
 STRUCTURAL
 MECH/ELEC/PLUMB

ARCHITECTS
 HOENER ASSOCIATES, INC.
 6707 PLAINVIEW AVENUE
 ST. LOUIS, MISSOURI 63109
 Ph. (314) 781-9855

ALL DIMENSIONS MUST BE VERIFIED AT BUILDING BEFORE WORK IS EXECUTED. THIS DRAWING IS THE PROPERTY OF THE ARCHITECTS AND SHALL NOT BE COPIED OR DUPLICATED WITHOUT THEIR CONSENT.

proj. no. 23-09C
date issued
 07 02 2024
date revised
 1 ADD#2 08/01/2024

drawn by NAM
checked by RAJ
sheet no.

E4.2
 SD-15

SUBMITTAL REVIEW

Date Received: 10/11/2018	Date Returned: 10/11/2018
Project Number: 104306.003	Reviewer: Alex Pugh
Project Name Orchard Farm School District ECC Addition	
Contractor Submittal Number	

We are returning the following submittals with action as noted:
 APPROVED (A)
 APPROVED AS CORRECTED (AAC)
 REVISE AND RESUBMIT (R&R)
 NOT APPROVED (NA)
 REVIEWED (R)

These documents were reviewed with the understanding that they were submitted after the contractor reviewed them and implicitly certified that they were in compliance in all respects with the requirements of the contract documents. Checking is only for conformance with the design concept of the project and compliance with the information given in the Contract Documents. Contractor is responsible for quantities; dimensions to be confirmed and correlated at the job site; for information that pertains solely to the fabrication processes or to techniques of construction; and for coordination of the work of all trades.

Description Comments	A	AAC	R&R	NA	R
Fire Protection - Resubmittal - No exceptions taken. +					✓



TRANSMITTAL OF SUBMITTAL

Wright Construction Services Inc
18-01-008 - Orchard Farm Early Learning Center Addition

DATE: 10/11/2018

TRANSMITTAL #:
61

To: Matt McDermott
Hoener Associates Inc.
6707 Plainview Avenue
St. Louis, MO 63109
Phone: 314-781-9855
Fax: 314-781-0163
Email: mmcdermott@hoenerarchitects.com
CC:

From: Bobby Christopher
Wright Construction Services Inc
11 Lami Industrial Dr
St. Peters, MO 63304
Phone: 636-220-6850
Fax: 636-220-6855
Email: bchristopher@wrightconstruct.com

Below are enclosed and/or attached submittal items for review. All items have been reviewed and are determined to be in accordance with their associated specification sections.

Please review and respond to Bobby Christopher.

DOC TYPE	SPEC. SECT. #: DESCRIPTION	COPIES	STATUS	REMARKS
Submittal Register	40:15000 - Fire Protection Resubmittal	1	Submitted	Revised Drawings

Additional Notes:

Bobby Christopher

DA SHEETS

TABLE OF CONTENTS

DIVISION 1 - GENERAL

1.01a-1.01b	TABLE OF CONTENTS
1.03	DA SHEET EXPLANATION
1.04-1.05	ABBREVIATIONS
1.06	REFERENCE SYMBOLS
1.07	REFERENCE SYMBOLS - SITE PLAN
1.08	MATERIAL INDICATIONS (IN SECTION)
1.09-1.11	TYPICAL MOUNTING HEIGHTS (INCLUDING ADA)
1.12	WALL TYPES
1.30	COLUMN MATRIX
1.31-1.38	COLUMN DETAILS
1.60	WALL INFILL DETAIL

DIVISION 2 - SITE WORK

2.02	EROSION BARRIER DETAIL
2.04a-2.04b	PIPE BEDDING DETAILS
2.06	SOIL REMOVAL DETAIL

DIVISION 3 - CONCRETE

3.01	TYPICAL DETAILS (FOUNDATION OFFSET, JOINTS, SIDEWALKS)
3.02-3.03	TYPICAL DOOR STOOP

DIVISION 4 - MASONRY

4.04	TYPICAL MECHANICAL OPENING LINTELS
4.08, 4.10	TYPICAL THRU-WALL FLASHING DETAILS
4.21	MASONRY SAMPLE PANEL

DIVISION 5 - METALS

5.03	EXPANSION JOINT DETAILS
------	-------------------------

DIVISION 6 - CARPENTRY

6.11	SECTION THRU SINKS - STANDARD ADA
6.12	TYPICAL SECTION THRU CASEWORK

DIVISION 7 - THERMAL & MOISTURE PROTECTION

7.02a	TYPICAL COUNTER FLASHING DETAIL AT METAL SIDING
7.02b	COUNTER FLASHING DETAIL AT EXPANSION JOINT
7.03	FASCIA & GUTTER DETAILS
7.04	DOWNSPOUT DETAIL
7.05	ROOF INTERSECTION DETAIL
7.10	SHEATHING AT LIGHT GAUGE TRUSS
7.11	EXPANSION JOINT @ VALLEY
7.12	EXPANSION JOINT @ VALLEY AT EXISTING WALL
7.24	SPLASH PAN DETAIL



HOENER ASSOCIATES, INC.
 ARCHITECTS
 ST. LOUIS, MISSOURI

MARK A. REUTHER
 LICENSE #006452

ARCHITECTURAL CORP.
 NO. 000193

PROJECT NO. 23-09C

BY: BF

DATE: 07/02/2024

REV.: SD-17

 ADD#2 08/01/24

DA: 1.01A

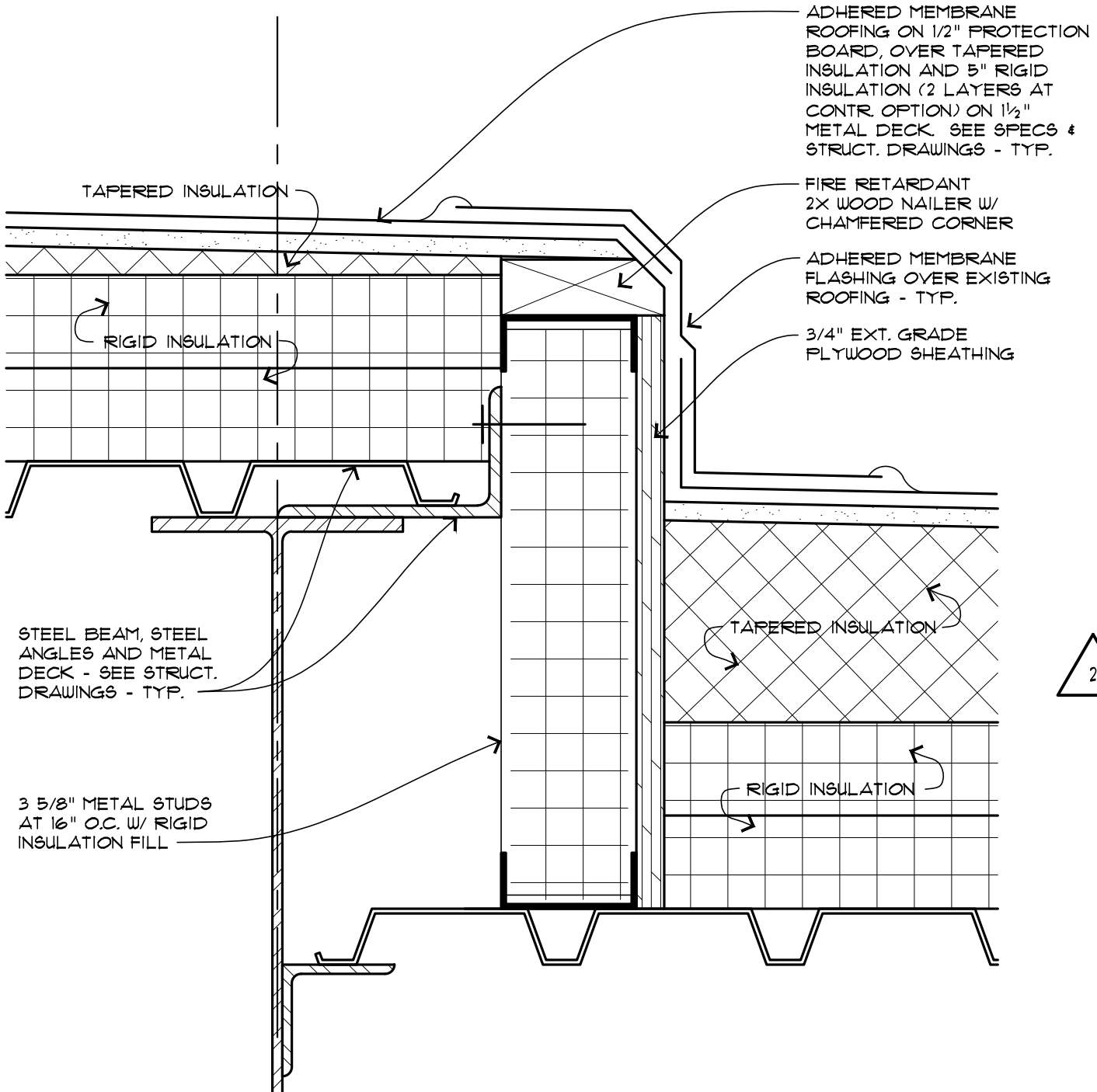

ADHERED MEMBRANE ROOFING ON 1/2" PROTECTION BOARD, OVER TAPERED INSULATION AND 5" RIGID INSULATION (2 LAYERS AT CONTR. OPTION) ON 1 1/2" METAL DECK. SEE SPECS & STRUCT. DRAWINGS - TYP.

FIRE RETARDANT 2X WOOD NAILER W/ CHAMFERED CORNER

ADHERED MEMBRANE FLASHING OVER EXISTING ROOFING - TYP.

3/4" EXT. GRADE PLYWOOD SHEATHING

TAPERED INSULATION

RIGID INSULATION

TAPERED INSULATION

RIGID INSULATION

STEEL BEAM, STEEL ANGLES AND METAL DECK - SEE STRUCT. DRAWINGS - TYP.

3 5/8" METAL STUDS AT 16" O.C. W/ RIGID INSULATION FILL

3" = 1'-0"

1
7.05

ROOF INTERSECTION DETAIL

2

SD-18

HOENER ASSOCIATES, INC.
ARCHITECTS
ST. LOUIS, MISSOURI

MARK A. REUTHER
LICENSE #006452

ARCHITECTURAL CORP.
NO. 000193

PROJECT NO. 23-09C

BY: BF

DATE: 07/02/2024

REV.: NEW SHEET

ADD#2 08/01/24

DA: 7.05

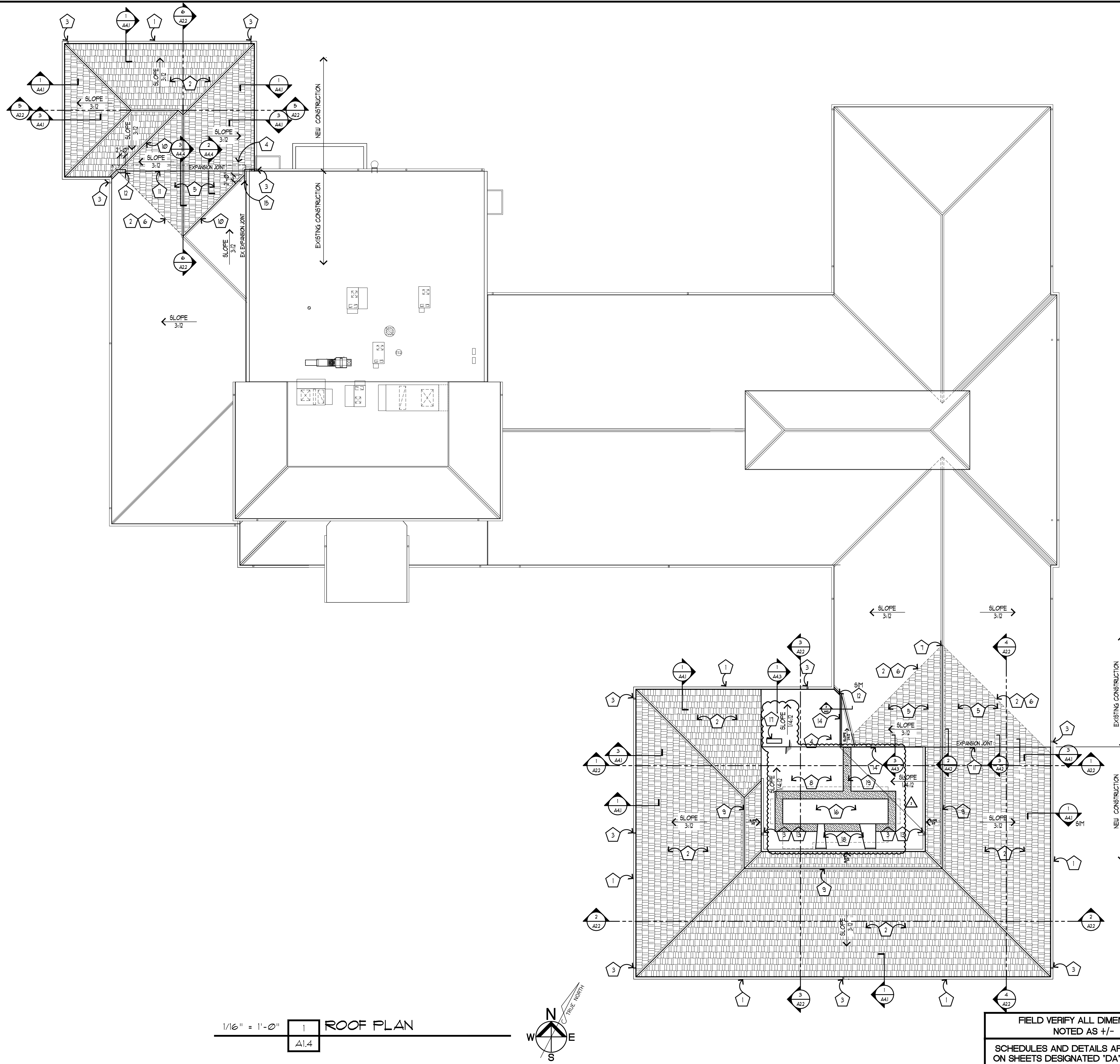

- ROOF PLAN KEYED NOTES**
- 1 PRE-FINISHED METAL GUTTER AND FASCIA.
 - 2 ASPHALT SHINGLE ROOF OVER ICE AND WATER SHIELD ON FIRE TREATED FLYD. SHEATHING. ALL OVER 5" RIGID INSUL. (2 LAYERS CONTRACTORS OPTION) ON 1/2" MTL. DECK. SEE SPECS AND STRUCT. DUGS.
 - 3 5" X 5" DOWNSPOUT. SEE CIVIL.
 - 4 REMOVE EXISTING DOWNSPOUT AND RELOCATE. SEE CIVIL.
 - 5 REMOVE EXISTING ROOFING DOWN TO DECK FOR INSTALLATION OF NEW TRUSSES. SEE STRUCT. G.C. TO ADD ICE AND WATER SHIELD AFTER ROOFING IS REMOVED TO PROTECT EXISTING BUILDING FROM WATER INFILTRATION.
 - 6 TIE NEW SHINGLES INTO EXISTING SHINGLES.
 - 7 FLASH NEW RIDGE LINE INTO EXISTING.
 - 8 ADHERED MEMBRANE ROOFING ON 1/2" PROTECTION BOARD, TAPERED INSUL. AND 5" RIGID INSUL. (2 LAYERS CONTRACTORS OPTION) ON 1/2" MTL. DECK. SEE SPECS AND STRUCT. DUGS.
 - 9 ROOF EDGE CAP.
 - 10 FLASH NEW SHINGLES W/ NEW VALLEY FLASHING. SEE DA 124.
 - 11 FLASH NEW SHINGLES W/ NEW EXPANSION JOINT FLASHING.
 - 12 FLASH NEW SHINGLES W/ NEW EXPANSION JOINT FLASHING AT VALLEY / OVERHANG. SEE DA 111.
 - 13 METAL SPASHPAN. SEE DA 124.
 - 14 ADHERED MEMBRANE FLASHING OVER SPONGE TUBE AT NEW EXPANSION JOINT. SEE WALL SECTIONS.
 - 15 FLASH NEW SHINGLES W/ NEW EXPANSION JOINT FLASHING AT VALLEY AND EXISTING WALL. SEE DA 111.
 - 16 ROOF TOP UNIT - SEE MECHANICAL DRAWINGS.
 - 17 ROOF TOP CONDENSING UNIT ON MAINTENANCE PAD - SEE MECHANICAL DRAWINGS.
 - 18 WATERPROOF INSULATED DUCTWORK ON SUPPORTS - SEE MECHANICAL DRAWINGS.
 - 19 ROOF WALK PADS - SEE SPECS.

1/16" = 1'-0" **1 ROOF PLAN**
A1.4

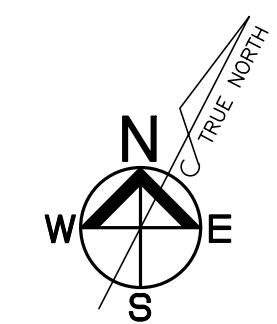

FIELD VERIFY ALL DIMENSIONS NOTED AS +/-
SCHEDULES AND DETAILS ARE LOCATED ON SHEETS DESIGNATED "DA" WHICH ARE BOUND SEPARATE FROM THE PROJECT SPECIFICATIONS.

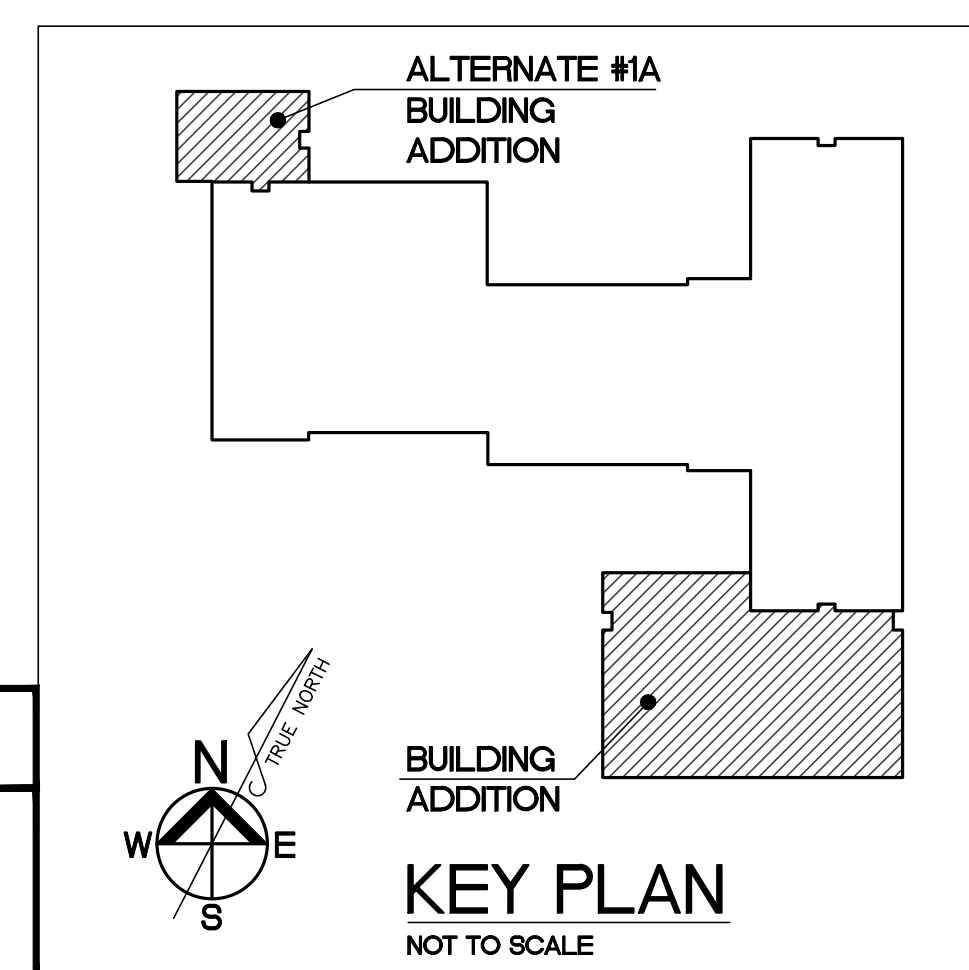

ADDITIONS AND RENOVATIONS TO:
EARLY LEARNING CENTER
3489 BOSCHERTOWN ROAD and ISLAND HARBOR DRIVE
ORCHARD FARM R-V SCHOOL DISTRICT ST. CHARLES COUNTY, MISSOURI

MARK A. REUTHER
LICENSE #006452

ARCHITECTURAL CORP.
NO. 000193

CONSULTING ENGINEERS:
CIVIL/SURVEY
STRUCTURAL
MECH/ELEC/PLUMB

ARCHITECTS:
BAX ENGINEERING
ASDC
McCLURE ENGINEERING

HOENER ASSOCIATES, INC. - ARCHITECTS
6707 PLAINVIEW AVENUE
ST. LOUIS, MISSOURI 63109
Ph. (314) 781-9855

ALL DIMENSIONS MUST BE VERIFIED AT BUILDING BEFORE WORK IS EXECUTED. THIS DRAWING IS THE PROPERTY OF THE ARCHITECTS AND SHALL NOT BE COPIED OR DUPLICATED WITHOUT THEIR CONSENT.

proj. no. 23-09C
date issued
JULY 02, 2024
date revised
ADD#2 08/01/24

drawn by **BF**
checked by **MR**
sheet no.

A1.4
SD-19

DOOR SCHEDULE

MISC. NOTE (IF REQ'D)

No.	FROM	TO	OPENING SIZE	DOOR TYPE	DOOR MAT.	FRAME TYPE	MINUTE RATING	HDWR. GROUP	REMARKS
300A	300	EXT.	(PAIR) 3'-4" X 7'-0"	E	MTL	M-3		2	SEE DA: 8.11
300B	300	EXT.	(PAIR) 3'-4" X 7'-0"	E	MTL	M-3		2	SEE DA: 8.12
303	302	303	3'-0" X 7'-0"	C	WD	M-1		6	SEE DA: 8.09
303A	303	303A	3'-0" X 7'-0"	B	WD	M-1		7	SEE DA: 8.09
303B	303	303B	3'-0" X 7'-0"	D	WD	M-1		5	SEE DA: 8.09
304	302	304	3'-0" X 7'-0"	C	WD	M-1		6	SEE DA: 8.09
304A	304	304A	3'-0" X 7'-0"	B	WD	M-1		7	SEE DA: 8.09
304B	304	304B	3'-0" X 7'-0"	D	WD	M-1		5	SEE DA: 8.09
305	302	305	3'-0" X 7'-0"	C	WD	M-1		6	SEE DA: 8.09
305A	305	305A	3'-0" X 7'-0"	B	WD	M-1		7	SEE DA: 8.09
305B	305	305B	3'-0" X 7'-0"	D	WD	M-1		5	SEE DA: 8.09
306	302	306	3'-0" X 7'-0"	C	WD	M-1		6	SEE DA: 8.09
306A	306	306A	3'-0" X 7'-0"	B	WD	M-1		7	SEE DA: 8.09
306B	306	306B	3'-0" X 7'-0"	D	WD	M-1		5	SEE DA: 8.09
309	308	309	3'-0" X 7'-0"	C	WD	M-1		6	SEE DA: 8.09
309A	309	309A	3'-0" X 7'-0"	B	WD	M-1		7	SEE DA: 8.09
309B	309	309B	3'-0" X 7'-0"	D	WD	M-1	△ 2	5	SEE DA: 8.09
310	308	310	3'-0" X 7'-0"	C	WD	M-1		6	SEE DA: 8.09
310A	310	310A	3'-0" X 7'-0"	B	WD	M-1		7	SEE DA: 8.09
310B	310	310B	3'-0" X 7'-0"	D	WD	M-1		5	SEE DA: 8.09
311	308	311	3'-0" X 7'-0"	C	WD	M-1		6	SEE DA: 8.09
311A	311	311A	3'-0" X 7'-0"	B	WD	M-1		7	SEE DA: 8.09
311B	311	311B	3'-0" X 7'-0"	D	WD	M-1		5	SEE DA: 8.09
312	308	312	3'-0" X 7'-0"	C	WD	M-1		6	SEE DA: 8.09
312A	312	312A	3'-0" X 7'-0"	B	WD	M-1		7	SEE DA: 8.09
312B	312	312B	3'-0" X 7'-0"	D	WD	M-1		5	SEE DA: 8.09



HOENER ASSOCIATES, INC.

ARCHITECTS

ST. LOUIS, MISSOURI

MARK A. REUTHER
LICENSE #006452

ARCHITECTURAL CORP.
NO. 000193

PROJECT NO. 23-09C

BY: **BF**

DATE: 07/02/2024

REV.: **SD-20**

△ **ADD#2 08/01/24**

DA: 8.01A

DOOR SCHEDULE

MISC. NOTE (IF REQ'D)

No.	FROM	TO	OPENING SIZE	DOOR TYPE	DOOR MAT.	FRAME TYPE	MINUTE RATING	HDWR. GROUP	REMARKS
313	300	313	3'-0" X 7'-0"	F	WD	M-2		10	SEE DA: 8.09/8.10
314	300	314	3'-0" X 7'-0"	F	WD	M-2		10	SEE DA: 8.09/8.10
315	300	315	3'-0" X 7'-0"	B	WD	M-1		10	SEE DA: 8.09
316	300	316	3'-0" X 7'-0"	F	WD	M-2		10	SEE DA: 8.09/8.10
317	300	317	3'-0" X 7'-0"	F	WD	M-2		10	SEE DA: 8.09/8.10
318	300	318	3'-0" X 7'-0"	F	WD	M-2		10	SEE DA: 8.09/8.10
ALTERNATE #1									
400A	401	EXT.	(PAIR) 3'-0" X 7'-0"	E	MTL	M-4		2	SEE DA: 8.12
400B	401	EXT.	(PAIR) 3'-0" X 7'-0"	E	MTL	M-4		2	SEE DA: 8.12
402	400	402	3'-0" X 7'-0"	F	WD	M-2		10	SEE DA: 8.09/8.10
403	400	403	3'-0" X 7'-0"	F	WD	M-2		10	SEE DA: 8.09/8.10
404	401	404	3'-0" X 7'-0"	F	WD	M-2		10	SEE DA: 8.09/8.10
405	401	405	3'-0" X 7'-0"	F	WD	M-2		10	SEE DA: 8.09/8.10
406	401	406	3'-0" X 7'-0"	F	WD	M-2		10	SEE DA: 8.09/8.10
407	406	407	3'-0" X 7'-0"	F	WD	M-1		10	SEE DA: 8.09
								△ 2	



HOENER ASSOCIATES, INC.
 ARCHITECTS
 ST. LOUIS, MISSOURI

MARK A. REUTHER
 LICENSE #006452

ARCHITECTURAL CORP.
 NO. 000193

BY: BF
 DATE: 07/02/2024
 REV.: SD-21
 △ 2 ADD#2 08/01/24
 DA: 8.01B

PROJECT NO. 23-09C